



OFFICE OF PUBLIC ART CHARLESTON, WEST VIRGINIA



REQUEST FOR PROPOSALS DOWNTOWN ELECTRICAL BOX PROJECT City of Charleston, WV

ABOUT THE PROJECT

The City of Charleston-Office of Public Art (COPA) in partnership with the City Center Business Improvement District (BID) are requesting proposals and qualifications from artists for vinyl wraps that will be installed on electrical boxes in downtown Charleston.

PROJECT GOALS

- To commission strong concepts that will enhance city infrastructure.

PROJECT TIMELINE

JULY 26, 2024 – RFP ANNOUNCED

SEPT 2, 2024 – RFP SUBMISSION DEADLINE

SEPT 6, 2024 – ANNOUNCE SELECTED ARTISTS

SEPT 20, 2024 - FINAL PRINT READY CONCEPTS DUE

OCT 1, 2024 - FINAL INSTALLATION COMPLETE (ARTIST IS NOT RESPONSIBLE FOR VINYL INSTALLATION)

COMPENSATION

Artist will be paid \$500.00 for final rendered concept design-executed, scaled, and print ready.

ELIGIBILITY

Candidates must be professional artists or designers, eligible to work in the United States, and age 18 or older. Candidates are eligible regardless of race, color, religion, national origin, gender, gender identification, military status, sexual orientation, marital status, or physical ability. You do not need to be a resident of Charleston or the state of West Virginia to make a submission.

SUBMISSION REQUIREMENTS

Submissions MUST include:

1. Title of Electrical Box Wrap with brief description of imagery meaning/concept
2. SINGLE page PDF or jpeg File of concept using the attached template.
3. The concept does NOT have to be the final print ready design. The concept must be a color rendering showing general aesthetic direction.
4. WORK SAMPLES: 3-5 images of previous work (single .jpegs or PDFs –do NOT combine)

INCOMPLETE SUBMISSIONS WILL NOT BE CONSIDERED

SELECTION CRITERIA

- Clarity of design
- Color choices
- Originality
- Integration

SELECTION PROCESS

A selection committee will consider the concept proposals submitted and make final artist selections.

OTHER CONSIDERATIONS:

The City of Charleston Office of Public Art shall retain ownership of the image, including but not limited to, reproduction rights, physical maintenance and lifespan. In all uses of the image, the creative product will be credited to the artist. All terms & conditions will be laid out in a contract to be signed by the artist upon selection of the artist.

Submission may be emailed to:

SUBJECT LINE: EB MURAL PROJECT (YOUR LAST NAME)

Jeff Pierson jeff.pierson@cityofcharleston.org

Questions: call Jeff at 304-348-8000 ext. 306

ABOUT THE CITY OF CHARLESTON OFFICE OF PUBLIC ART (COPA)

The City of Charleston's Office of Public Art was created to be a resource for the conservation, education, and the creation of Public Art in Charleston, WV. COPA was established to create an environment for public art to thrive. Through its programming and working with our local artists, COPA has brought an elevated vitality to the City of Charleston. Since its creation in 2017, COPA has served in resources over 130 new Public Art Commissions.

Public Art can be a tool for community engagement and collective pride. It brings opportunities to arts, engages student learning, and helps public awareness on community and social issues.

ABOUT THE CITY CENTER BUSINESS IMPROVEMENT DISTRICT(BID)

Formed in 2021, The City Center Business Improvement District (BID) consists of private property owners assessing themselves fees to address the goals of enhancing economic stability, providing an active, thriving and inclusive downtown, encourage historic preservation and investing in sound, sustainable infrastructure and civic amenities in a portion of downtown Charleston, WV. The BID is supported by 37 property owners investing in the BID district which includes parts of Summers Street, Lee Street, Court Street and Virginia Street. A phased Master Plan and Economic Analysis was completed in late 2023 which focuses on placemaking improvements, streetscape enhancements, safety and security and marketing opportunities.

PROJECT PARTIALLY FUNDED BY THE CITY CENTER BUSINESS IMPROVEMENT DISTRICT(BID)

LOCATIONS



CONCEPT SPECIFICATIONS

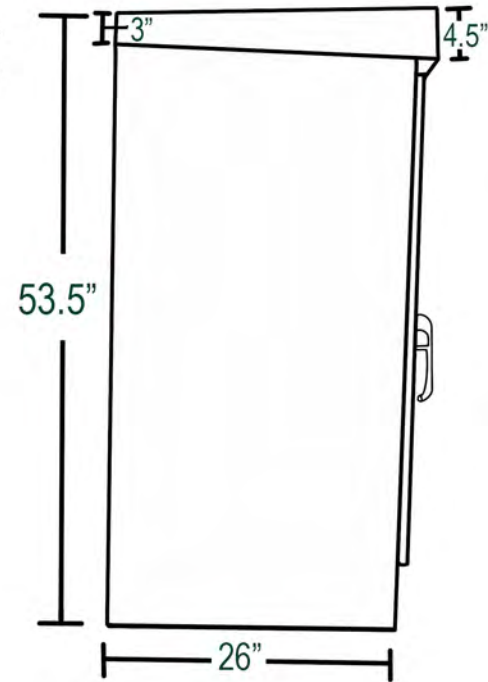
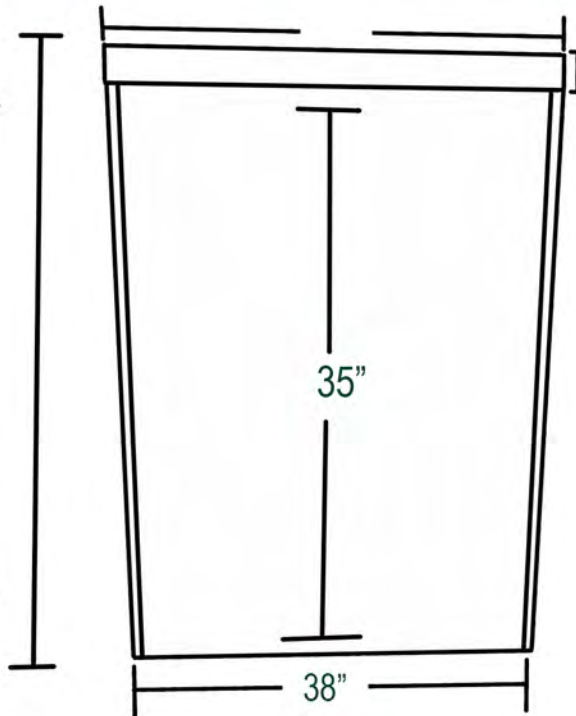
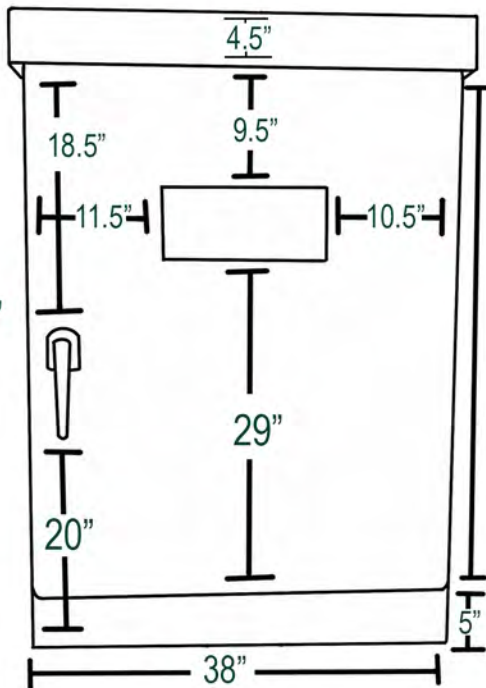
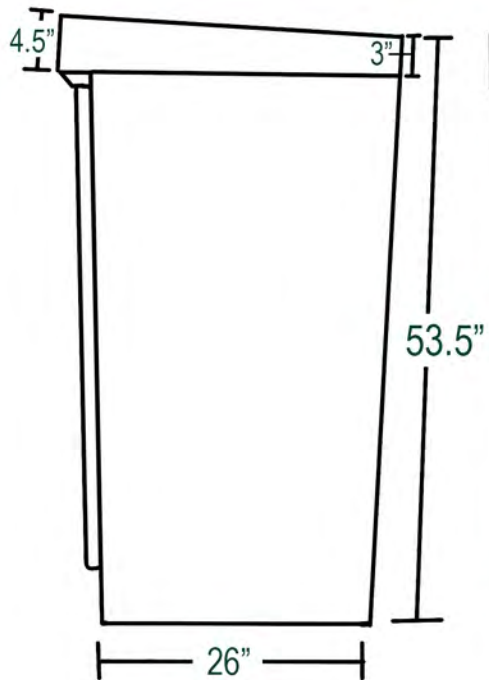

SUBMISSION SAMPLE



IMAGE FOR SAMPLE PURPOSES ONLY. NOT A SUGGESTION OF THEMATIC, CONCEPTUAL, OR AESTHETIC DIRECTION

