

REQUEST FOR QUOTATION
CITY OF CHARLESTON
2026-27 ADA Ramp Installation Project (E6 05/26-163)

GENERAL CONSTRUCTION SPECIFICATIONS

1. **PURPOSE AND SCOPE:** The City of Charleston, WV (the City) is soliciting bids for the construction and/or reconstruction of curb ramps within public right-of-way in accordance with PROWAG accessibility standards.

Event	Date	Time
RFQ Issued	May 11, 2026	-
Pre-Bid (if necessary)	May 19, 2026	1:00pm
Deadline for Written Questions	May 20, 2026	1:00pm
Addendum Issued (if necessary)	May 21, 2026	1:00pm
Bid Opening	May 26, 2026	1:00pm

2. **DEFINITIONS:** The terms listed below shall have the meanings assigned to them below. Additional definitions can be found in Section 2 of the General Terms and Conditions.

2.1 **“Construction Services”** means installation of concrete sidewalk and accessible ramps as more fully described in these specifications.

2.2 **“Pricing Page”** means the pages upon which Vendor should list its proposed price for the Construction Services, commonly referred to as a quote.

2.3 **“Solicitation”** means the official notice of an opportunity to supply the City of Charleston, WV with goods or services that is published on the City’s website located at <https://charlestonwv.gov/bids-purchasing/current-bids>

3. GENERAL REQUIREMENTS:

Project Intent: The 2026 ADA Ramp Installation Project shall consist of the replacement of existing concrete curb and adjacent sidewalk throughout various locations within the City of Charleston. All work shall comply with the Public Right-of-Way Accessibility Guidelines (PROWAG), Chapter R3: Technical Requirements. This work shall include the furnishing of all material, labor, tools, and equipment necessary to complete and protect all phases of the work performed as shown upon the attached details and in accordance with these specifications.

All specifications are minimum requirements unless otherwise stated. Any deviations from the stated specifications must be described in detail. The merit of such deviations will be considered with regard to the City of Charleston’s intended use.

The Work under this Contract is divided into two phases as identified in the List of Locations. The City intends to award the Contract for both phases. Upon award, the Contractor shall proceed with the Work upon issuance of the Notice to Proceed. Phase 2 work may be performed prior to July 1, 2026; however, the City shall not be obligated to make payment for Phase 2 until after

REQUEST FOR QUOTATION
CITY OF CHARLESTON
2026-27 ADA Ramp Installation Project (E6 05/26-163)

July 1, 2026, when the City's new fiscal year begins and funds are appropriated and available for disbursement. The City will issue payment for Phase 2 work in accordance with the Contract after July 1, 2026.

Phase 1 of the Project shall be substantially complete within six (6) weeks after issuance of the Notice to Proceed. Phase 2 of the Project shall be substantially complete within seven (7) months after issuance of the Notice to Proceed.

3.01. Concrete Ramp and Sidewalk

3.01.01. Description

This work shall consist of excavation and removal of existing materials to the grade necessary for new construction, furnishing and placing all necessary concrete as shown on the plans, and grooming and seeding adjacent soils.

3.01.02. Construction Methods

Class B concrete with a minimum 28-day compressive strength of 3,000 psi and a minimum 5-inches thickness shall be used for construction of the sidewalks and ramps. Construction shall be in accordance with the 2023 WVDOH Standard Specifications for Roads and Bridges, Section 609-Sidewalks, Public Right-of-Way Accessibility Guidelines (PROWAG) requirements and the attached details.

Bedding shall consist of 5-inches of crushed limestone compacted to a dense and non-yielding condition, equivalent to approximately 95% of the maximum density as determined by the Standard Proctor Method.

All exposed concrete surfaces shall have a light broom finish transverse to the line of traffic and free of voids and defects. The contractor shall be responsible for protecting the finished surface during the initial curing period from tampering. Any damaged or tampered sidewalk, at the discretion of the City Engineer, shall be repaired or replaced at no additional cost to the City.

All streets, alleys, driveways, curbs and sidewalks are to be saw-cut and have a smooth edge free of jagged and rough edges.

The voids between the newly poured concrete and the street shall be backfilled with Class B concrete. The backfill shall be 1½" lower than the street elevation to receive asphalt.

All sidewalks and base course at driveway, street, and alley crossings shall be a minimum of 8-inches thick.

Earthwork shall consist of furnishing and spreading soil, straw, seed and fertilizer on all disturbed areas. The soil shall be free of rocks and debris. The straw, seed and

REQUEST FOR QUOTATION
CITY OF CHARLESTON
2026-27 ADA Ramp Installation Project (E6 05/26-163)

fertilizer shall be distributed according to the manufacturer's recommendations. Grass seed shall consist of Kentucky 31 Fescue mix.

3.01.03. Method of Measurement and Payment

Excavation, forming and placement of concrete, backfilling of soil, grooming and seeding and other items incidental to proper construction will be measured and paid on a unit-basis bid for Item 3.01 - Concrete Ramp and Sidewalk

3.02. Curb and Gutter

3.02.01. Description

This work shall consist of excavation and the removal of all materials encountered, furnishing and placing all necessary concrete and reinforcing steel as shown on the plans.

3.02.02. Construction Method

Class B concrete with a minimum 28-day compressive strength of 3,000 psi shall be used for construction of the curb and gutter. The top of the new curb shall match the elevation of the new or existing sidewalk except in those cases where extending the curb above the sidewalk is deemed necessary by the City Engineer. Slope of the gutter shall match the grade of the existing pavement. Construction shall be in accordance with the 2023 WVDOH Standard Specifications for Roads and Bridges, Section 610-Curbs, Combination Curbs and Gutters and Medians and the attached details.

Bedding shall consist of 5-inches of crushed limestone compacted to a dense and non-yielding condition, equivalent to approximately 95% of the maximum density as determined by the Standard Proctor Method.

All exposed concrete surfaces shall have a light broom finish and free of voids and defects. The contractor shall be responsible for protecting the finished surface during the initial curing period from tampering. Any damaged or tampered sidewalk, at the discretion of the City Engineer, shall be repaired or replaced at no additional cost to the City.

All streets, alleys, driveways, curbs and sidewalks are to be saw-cut and have a smooth edge free of jagged and rough edges.

The voids between the newly poured curb and gutter and the street shall be backfilled with Class B concrete. The backfill shall be 1/2" lower than the gutter and street elevation to receive asphalt.

3.02.03. Method of Measurement and Payment

REQUEST FOR QUOTATION
CITY OF CHARLESTON
2026-27 ADA Ramp Installation Project (E6 05/26-163)

Excavation, forming and placement of concrete, saw-cutting streets and driveways, and other items incidental to proper construction will be measured and paid on a unit-basis bid for Item 3.02 - Curb and Gutter.

3.03. Integral Curb

3.03.01. Description

This work shall consist of excavation and the removal of all materials encountered, furnishing and placing all necessary concrete and reinforcing steel as shown on the plans.

3.03.02. Construction Method

Class B concrete with a minimum 28-day compressive strength of 3,000 psi shall be used for construction of the integral curb. The top of the new curb shall match the elevation of the new sidewalk. Construction shall be in accordance with the 2023 WVDOH Standard Specifications for Roads and Bridges, Section 610-Curbs, Combination Curbs and Gutters and Medians and the attached details.

Bedding shall consist of 5-inches of crushed limestone compacted to a dense and non-yielding condition, equivalent to approximately 95% of the maximum density as determined by the Standard Proctor Method.

All exposed concrete surfaces shall have a light broom finish and free of voids and defects. The contractor shall be responsible for protecting the finished surface during the initial curing period from tampering. Any damaged or tampered sidewalk, at the discretion of the City Engineer, shall be repaired or replaced at no additional cost to the City.

All streets, alleys, driveways, curbs and sidewalks are to be saw-cut and have a smooth edge free of jagged, rough or sharp edges.

The voids between the newly poured curb and the street shall be backfilled with Class B concrete with a compressive strength as that of the integral curb. The backfill shall be 1½" lower than the street elevation to receive asphalt.

3.03.03. Method of Measurement and Payment

Excavation, forming and placement of concrete, saw-cutting streets and driveways and other items incidental to proper construction will be measured and paid on a unit-basis bid for Item 3.03 - Integral Curb.

3.04. Plain Curb

3.04.01. Description

REQUEST FOR QUOTATION
CITY OF CHARLESTON
2026-27 ADA Ramp Installation Project (E6 05/26-163)

This work shall consist of excavation and the removal of all materials encountered, furnishing and placing all necessary concrete and reinforcing steel as shown on the plans.

3.04.02. Construction Method

Class B concrete with a minimum 28-day compressive strength of 3,000 psi shall be used for construction of the plain curb. The top of the new curb shall match the elevation of the new sidewalk except in those cases where extending the curb above the sidewalk is deemed necessary by the City Engineer. Construction shall be in accordance with the 2023 WVDOH Standard Specifications for Roads and Bridges, Section 610-Curbs, Combination Curbs and Gutters and Medians and the attached details.

All exposed concrete surfaces shall have a light broom finish and free of voids and defects. The contractor shall be responsible for protecting the finished surface during the initial curing period from tampering. Any damaged or tampered sidewalk, at the discretion of the City Engineer, shall be repaired or replaced at no additional cost to the City.

All streets, alleys, driveways, curbs and sidewalks are to be saw-cut and have a smooth edge free of jagged, rough or sharp edges.

The voids between the newly poured curb and the street shall be backfilled with Class B concrete. The backfill shall be 1½” lower than the street elevation to receive asphalt.

3.04.03. Method of Measurement and Payment

Excavation, forming and placement of concrete, saw-cutting streets and driveways and other items incidental to proper construction will be measured and paid on a unit-basis bid for Item 3.04 - Plain Curb.

3.05. Detectable Warning Surfaces

3.05.01. Description

This work includes the furnishing of all materials, tools and other equipment necessary for the installation of detectable warning surfaces at each accessible ramp location.

3.05.02. Construction Method

Contractor shall install 24”x48” (min.) plastic set-in-place detectable warning panels for wet concrete and plastic surface mount detectable warning panels for cured concrete. The color shall be brick red. Detectable warning panels shall be from an

REQUEST FOR QUOTATION
CITY OF CHARLESTON
2026-27 ADA Ramp Installation Project (E6 05/26-163)

ADA certified manufacturer meeting Public Right-of-Way Accessibility Guidelines (PROWAG) requirements. Installation shall be in accordance with the manufacturer's specifications and the 2023 WVDOH Standard Specifications for Roads and Bridges, Section 609-Sidewalks.

3.05.03. Method of Measurement and Payment

All material and tools necessary and other items incidental to the proper placement of the detectable warning system will be measured and paid on a unit-basis bid for Item 3.05 - Detectable Warning Surfaces.

3.06. Curb Inlet Adjustment

3.06.01. Description

This work includes the furnishing of all materials, tools and other equipment necessary for the adjustment of curb inlet tops as may be necessary for the proper installation of curbs, ramps and sidewalk.

3.06.02. Construction Method

Construction shall be in accordance with the 2023 WVDOH Standard Specifications for Roads and Bridges, Section 605-Manholes and Inlets.

3.06.03. Method of Measurement and Payment

Excavation, saw-cutting, grout, backfill and other items incidental to proper construction will be measured and paid on a unit-basis bid for Item 3.06 - Curb Inlet Adjustment.

3.07. Asphalt Replacement

3.07.01. Description

This work includes the furnishing of asphalt, tools, milling grinder, rollers and other equipment necessary for the proper placement of asphalt at locations where streets may have been saw-cut or damaged during the excavation of curbs and sidewalk. Contractor shall be responsible for any asphalt removal that may be required up to 4 ft. from curb line into the street to correct any street to ramp grade irregularities, drainage issues, etc. to ensure public safety.

3.07.02. Construction Method

Asphalt shall be obtained from a supplier approved by the WVDOH and shall be compacted to a dense and non-yielding condition of 1½" thickness.

3.07.03. Method of Measurement and Payment

REQUEST FOR QUOTATION
CITY OF CHARLESTON
2026-27 ADA Ramp Installation Project (E6 05/26-163)

All material and tools necessary and other items incidental to the proper placement of the asphalt will be measured and paid on a unit-basis bid for Item 3.07 - Asphalt Replacement.

3.08. Traffic Control

3.08.01. Description

This work shall include but not limited to the furnishing of cones, signs, barricades, flashing lights, flaggers, etc. on site to ensure public safety. Contractor shall submit traffic control plans for the purpose of obtaining a temporary street closure permit from the City Traffic, Parking & Transportation (TPT) Department. No fee will be required for the permit. Local residents shall be notified of traffic and parking disruptions prior to beginning work.

3.08.02. Construction Method

Traffic control shall be in accordance with the 2006 WVDOT Temporary Traffic Control for Streets and Highways.

3.08.03. Method of Measurement and Payment

All material, tools and equipment necessary and other items incidental for proper traffic control will be measured and paid on a unit-basis bid for Item 3.08 - Traffic Control. Partial payments will be made as the work progresses in accordance with the following schedule.

- Twenty Five percent (25%) of the amount bid for Traffic Control will be released to the Contractor in quarterly increments of the Total Project completion.

3.09. Allowances

3.09.01. Description

This section specifies procedures for Allowances which shall be included in the contract price. Allowances have been established to accommodate for, at a later date, the actual cost for unanticipated work which the exact quantity cannot be determined at the time of bidding and to defer the selection of actual materials, labor and equipment. The price bid for Item 3.09 - Allowances has been set at \$10,000.

3.09.02. Material & Methods

Utilization of Allowances will not be allowed without prior approval of the City. Unanticipated work will be accounted for by unit bid prices, an agreed upon lump sum, or the actual cost of labor, materials, rental and/or other applicable costs. Coordinate materials and their installation for each allowance with related materials

REQUEST FOR QUOTATION
CITY OF CHARLESTON
2026-27 ADA Ramp Installation Project (E6 05/26-163)

and installations to ensure that each allowance item is completely integrated with related work.

3.09.03. Measurement & Payment

A lump sum for Allowances has been provided for the City's contingency fund to be used as the City directs. Allowances will be paid in a manner agreed upon with the Contractor. If there is no unanticipated work, then the Allowances will not be utilized or paid.

4. **CONTRACT AWARD:** The Contract is intended to provide the City with a purchase price for the Construction Services. The Contract will be awarded to the lowest qualified responsible bidder meeting the required specifications. If the Pricing Pages contain alternates/add-ons, the Contract will be awarded based on the grand total of the base bid and any alternates/add-ons selected.
5. **SELECTION OF ALTERNATES:** Pursuant to W. Va. Code § 5-22-1(f), any solicitation of bids shall include no more than five alternates. Alternates, if accepted, shall be accepted in the order in which they are listed on the bid form. Any unaccepted alternate contained within a bid shall expire 90 days after the date of the opening of bids for review. Determination of the lowest qualified responsible bidder shall be based on the sum of the base bid and any alternates accepted.
6. **PERFORMANCE:** Vendor shall perform the Construction Services in accordance with this document and the Project Plans.
7. **SUBSTITUTIONS:** Any substitution requests must be submitted in accordance with the official question and answer period described in the INSTRUCTIONS TO VENDORS SUBMITTING BIDS, Paragraph 3. Vendor Question Deadline. Vendors submitting substitution requests should submit product brochures and product specifications during the official question and answer period.
8. **PROJECT PLANS:** The checked box will apply to Project Plans for this solicitation.
 No Additional Project Plan Documents: There are no additional Project Plans other than those attached hereto as exhibits (including any ramp detail sheets) or as may be provided by subsequent addenda.

Additional Project Plan Documents: There are additional Project Plan documents other than those attached as exhibits. If this box is checked in a future addendum, copies of the additional Project Plan documents can be obtained by contacting the entity identified in that addendum.

REQUEST FOR QUOTATION
CITY OF CHARLESTON
2026-27 ADA Ramp Installation Project (E6 05/26-163)

9. CONDITIONS OF THE WORK

9.01. Permits: The Vendor shall provide all necessary permits and licenses to comply with all applicable Federal, State, or Local laws, regulations and ordinances of any regulating body.

9.02. Existing Conditions: If discrepancies are discovered between the existing conditions and those noted in the specifications, Vendor must immediately notify the City's representative. Vendor must also immediately notify the City if suspected hazardous materials are encountered.

9.03. Standard Work Hours: The standard hours of work for this Contract will be Monday through Friday, 8am to 5pm EST excluding holidays recognized by the City of Charleston. Any work outside of the standard hours of work must be approved in advance at the City's sole discretion. Authorization of work outside of the standard hours of work will not entitle Vendor to additional compensation.

9.04. Project Closeout: Project Closeout shall include the following:

9.04.01. Final Cleanup: It shall be the responsibility of the vendor to always keep the construction area clean from trash and debris. Vendor shall take measures to protect all utility and manhole lids from concrete splatter during each pour ensuring future accessibility. The final cleanup shall be reviewed by the City Engineer prior to final payment.

9.04.02. Final Inspection: Vendor shall participate in a final inspection with the City's project manager. The purpose of the final inspection will be to identify deficiencies that need to be remedied prior to the City's final acceptance of the work. Vendor shall always be obligated to perform in accordance with the Contract and must take all actions necessary to ensure that work complies with requirements of Contract prior to final acceptance. Final acceptance does not waive or release Vendor from its obligation to ensure that work complies with the Contract requirements. Vendor shall submit any warranty documents to the City project manager at final inspection.

10. FACILITIES ACCESS: Performance of Contract Services may require access cards and/or keys to gain entrance to the City's facilities. In the event that access cards and/or keys are required:

1. Vendor must identify principal service personnel which will be issued access cards and/or keys to perform service.

REQUEST FOR QUOTATION
CITY OF CHARLESTON
2026-27 ADA Ramp Installation Project (E6 05/26-163)

2. Vendor will be responsible for controlling cards and keys and will pay replacement fee, if the cards or keys become lost or stolen.
3. Vendor shall notify the City immediately of any lost, stolen, or missing card or key.
4. Anyone performing under this Contract will be subject to the City's security protocol and procedures.
5. Vendor shall inform all staff of City's security protocol and procedures.

10. MISCELLANEOUS:

10.1. Contract Manager: During its performance of this Contract, Vendor must designate and maintain a primary contract manager responsible for overseeing Vendor's responsibilities under this Contract. The Contract manager must be available during normal business hours to address any customer service or other issues related to this Contract. Vendor should list its Contract manager and his or her contact information below.

Contract Manager: _____

Telephone Number: _____

Fax Number: _____

Email Address: _____

REQUEST FOR QUOTATION
CITY OF CHARLESTON
2026-27 ADA Ramp Installation Project (E6 05/26-163)

PRICING PAGE

We agree to sell and perform for the City of Charleston the above project as described in the attached specifications for the price listed below:

Description	Unit	Quantity	Unit Cost	Item Total
Item 3.01. – Concrete Ramp and Sidewalk	SF	20,500		
Item 3.02. – Curb and Gutter	LF	550		
Item 3.03. – Integral Curb	LF	2,600		
Item 3.04. – Plain Curb	LF	500		
Item 3.05. – Detectable Warning Surfaces	EA	175		
Item 3.06. – Curb Inlet Adjustment	EA	10		
Item 3.07. – Asphalt Replacement	Ton	40		
Item 3.08. – Traffic Control	LS	1		
Item 3.09. – Allowances	LS	1	\$10,000	\$10,000
			BASE BID	
			TOTAL:	

All items required for project completion but not listed separately shall be considered incidental to the items shown. Quantities are estimates for bidding purposes only; the City of Charleston will only pay for actual quantities installed. The City of Charleston reserves the right to vary quantities up to 50% with no increase in unit price. Specified ramp types and locations are subject to change during construction.

REQUEST FOR QUOTATION
CITY OF CHARLESTON
2026-27 ADA Ramp Installation Project (E6 05/26-163)

General List of Locations

Phase I

Bullitt St. Alley-2

Bullitt/Piedmont Rd-3

Park Ave/RR-2

Central Ave/ Glenwood Ave.-4

Chesterfield Ave./31st St.-2

Chesterfield Ave./33rd St.-5 (include a 6-ft island)

Edgewood Dr./Wood Rd.-2 (eliminate existing non-compliant ramps)

Total 20

Phase 2

Temple St. / Red oak St. -2

Temple St. / Clay Ave - 2

Burgess St. / Red oak St. - 1

Buena vista Pl./ orchard St. - 2

Fitzgerald St. / 2nd Ave - 6

Fitzgerald St./ alleys between grant and 2nd Ave - 3

Fitzgerald St./ Grant St. - 2

Grant St. / Marion Ave - 3

Grant St. / Fitzgerald St. - 2

Grant St./ Russell St. 1 - 3

Grant St./ Russell St. - 2

Stockton St./ Madison St. - 2

REQUEST FOR QUOTATION
CITY OF CHARLESTON
2026-27 ADA Ramp Installation Project (E6 05/26-163)

Stockton St./ alley between Madison St. and 6th Ave – 2

Stockton St. / 6th av.- 6

Stockton St. / alleys between 6th Ave and 7th Ave – 4

Greendale Dr / alley behind women's clinic – 2

Greendale Dr / Branch St. – 2

Park Ave / alley between 6th St. and 7th St. – 4

Delaware Ave. / Kan. Blvd – 2

Delaware Ave. / Simms St – 2

Delaware Ave. / Hall St – 2

Delaware Ave. / Berkeley St – 2

Delaware Ave. / Alley Between Berkeley and Grant – 2

Delaware Ave. / Grant St – 2

Delaware Ave. / ally between Grant and Monongalia – 2

Delaware Ave. / Monongalia St. – 4

Delaware Ave. / Main St. – 2

Wyoming St / Tennessee Ave. – 5

Wyoming St / alley across from Salvation Army thrift store #1 – 4

Wyoming St / alley across from Salvation Army thrift store #2 – 3

Wyoming St / Ohio Av. – 5

Oakwood Rd. / Jordan Pl. – 2

Oakwood Rd. / corner of Overbrook school – 1

Oakwood Rd. / in front of Overbrook school – 2

Oakwood Rd. / corner of Overbrook school – 1

Ruffner Ave. / alley between Jackson and Lewis St.- 2

REQUEST FOR QUOTATION
CITY OF CHARLESTON
2026-27 ADA Ramp Installation Project (E6 05/26-163)

Ruffner Ave. / Jackson St. – 4

Ruffner Ave / alley between Jackson and Washington St. E - 4

Ruffner Ave. / alleys between Washington and lee St. – 4

Ruffner Ave. / Lee St. – 4

Quarrier St. / Dunbar St. – 5

Quarrier St. / McFarland – 4

Court St. / United Way Square – 2

Total 122

PHASE 1 & 2 TOTAL: 142 RAMP REPLACEMENTS

NOTE:

List is subject to change based on modifications to the paving list.

REQUEST FOR QUOTATION
CITY OF CHARLESTON
2026-27 ADA Ramp Installation Project (E6 05/26-163)

PROJECT PLANS

Project Plans Begin on Next Page

NOTES

THE TYPE OF RAMP TO BE USED SHALL BE AS SPECIFIED ON THE PLANS. THESE STANDARDS CAN BE CONSIDERED GUIDELINES IN SELECTING RAMP TYPES, HOWEVER THEY CAN BE DEVIATED FROM WITH A SPECIAL DETAIL AS NOTED IN PLANS.

RAMP CONCRETE SHALL MEET THE REQUIREMENTS OF SECTION 609 OF THE CURRENT WVDOT, DOH STANDARD SPECIFICATIONS ROADS AND BRIDGES AND ANY SUBSEQUENT DOH SUPPLEMENTAL SPECIFICATIONS, AND THE PUBLIC RIGHTS OF WAY ACCESSIBILITY GUIDELINES (PROWAG) DATED JULY 26, 2011. RAMP SURFACE SHALL INCLUDE A "DETECTABLE WARNING SURFACE" (SEE PVT7 SHT. 11 OF 13) AS SHOWN FOR EACH RAMP TYPE. A COARSE BROOM FINISH, TRANSVERSE TO FLARE SLOPES, OR EQUAL NON-SKID FINISH SHALL BE PROVIDED ON CONCRETE SURFACES.

NORMAL GUTTER FLOW LINE AND PROFILE SHALL BE MAINTAINED THROUGH THE RAMP AREA, UNLESS OTHERWISE SHOWN OR SPECIFIED. POSITIVE DRAINAGE MUST BE MAINTAINED SO THAT NO PONDING OCCURS WITHIN THE RAMP OR CLEAR SPACE AREA.

1/4" MINIMUM, 1/2" MAXIMUM PREFORMED EXPANSION JOINT FILLER, MEETING THE REQUIREMENTS OF SECTION 609 OF THE SPECIFICATIONS, AS NOTED ABOVE, SHALL BE PLACED AT ALL LOCATIONS WHERE RAMP CONTACTS CURB, GUTTER, CONCRETE PAVEMENT, OR OTHER RIGID OBJECTS.

WHERE EXISTING SIDEWALK CONNECTS TO PROPOSED SIDEWALK OR RAMPS, EXPANSION JOINTS ALONG WITH DOWEL BARS WILL BE PLACED. DOWEL BARS WILL BE UTILIZED BETWEEN EXISTING AND PROPOSED TO REDUCE VERTICAL CHANGE. SEE SHEET 11 FOR ADDITIONAL INFORMATION.

SAWCUTS WILL BE UTILIZED DURING DEMOLITION OF EXISTING SIDEWALKS. SIMILAR METHODS MAY BE USED UPON APPROVAL BY FIELD ENGINEER.

RAMPS SHALL NOT BE PLACED IN LINE WITH DRAINAGE STRUCTURES. LOCATION OF THE RAMP SHALL TAKE PRECEDENCE OVER LOCATION OF THE DRAINAGE STRUCTURE, EXCEPT WHERE EXISTING STRUCTURES ARE BEING UTILIZED FOR CONSTRUCTION OF NEW RAMPS.

ANY GRATE IN PEDESTRIAN AREAS SHALL HAVE OPENINGS NOT GREATER THAN 1/2" AND SHALL BE PLACED WITH LONG DIMENSION OF OPENING PERPENDICULAR TO THE DIRECTION OF PEDESTRIAN TRAVEL.

IF THE 8.33% (12:1) SLOPE CANNOT BE OBTAINED DUE TO GRADE OF THE ADJACENT ROADWAY, THE SLOPED PORTION OF THE RAMP SHALL BE EXTENDED TO A MINIMUM LENGTH OF 15'-0".

EXISTING CROSS WALK AND STOP BAR MARKINGS TO BE ERADICATED AND RELOCATED AS DICTATED BY PROPOSED RAMP LOCATIONS. COST NOT INCIDENTAL TO COST OF PROPOSED RAMP.

CURB RAMP WIDTH SHALL MATCH SIDEWALK WIDTH PLUS CLEARANCE. TYPICAL SIDEWALK WIDTH IS 5' MINIMUM. RAMP WIDTHS LESS THAN 5' REQUIRE DIVISION/DISTRICT ENGINEER APPROVAL. WIDTHS LESS THAN 4' REQUIRE AN EXCEPTION JUSTIFICATION REPORT. SEE SHEET 11 FOR INFORMATION REGARDING RAMP THICKNESS.

GRADE BREAKS SHALL BE PERPENDICULAR TO THE DIRECTION OF THE RAMP RUN. SURFACE SLOPES THAT MEET AT GRADE BREAKS SHALL BE FLUSH.

CLEAR SPACE- BEYOND THE BOTTOM GRADE BREAK, A CLEAR SPACE THE WIDTH OF THE CURB RAMP AND EXTENDING 4' MINIMUM INTO THE ABUTTING ROADWAY SHALL BE PROVIDED WITHIN THE WIDTH OF THE PEDESTRIAN STREET CROSSING AND WHOLLY OUTSIDE THE PARALLEL TRAVEL LANE. SURFACE TO MATCH EXISTING. ANY CLEAR SPACE WORK TO BE COMPLETED WILL BE INCIDENTAL TO THE COST OF THE RAMP.

ALL CURB RAMPS SHALL BE CONSTRUCTED TO PROVIDE ACCESS TO EXISTING OPERABLE PARTS. AN EXAMPLE OF THIS WOULD BE PEDESTRIAN PUSH BUTTONS.

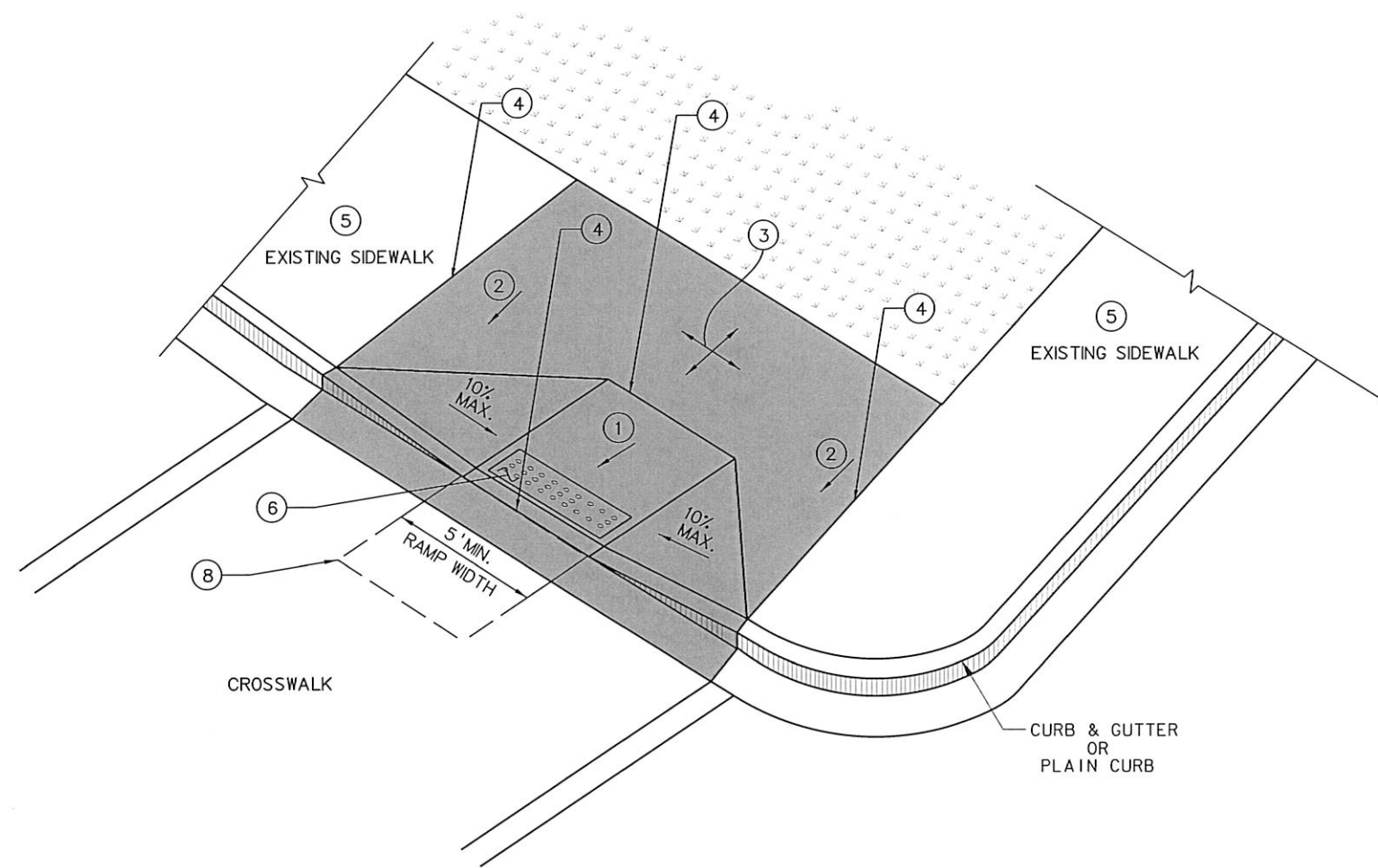

TYPE I RAMP

LEGEND

- ① 8.33% (12:1) MAXIMUM RAMP SLOPE INCLUDING CONSTRUCTION TOLERANCE
SLOPE OF RAMP SHALL CARRY THROUGH TO FACE OF CURB
- ② CROSS SLOPE: 2.00% MAXIMUM INCLUDING CONSTRUCTION TOLERANCE
- ③ CURB RAMPS REQUIRE A (5'-0") MINIMUM TURNING SPACE WHERE PEDESTRIANS
PERFORM TURNING MANEUVERS WITH A MAXIMUM CROSS SLOPE OF 2% AND
LONGITUDINAL SLOPE MATCHING ROADWAY
- ④ GRADE BREAK REQUIRED TO BE FLUSH (0") AND PERPENDICULAR TO
PEDESTRIAN PATH OF TRAVEL
- ⑤ IF SIDEWALK IS EXISTING AND NON-COMPLIANT SEE "TRANSITION
TO EXISTING NON-COMPLIANT SIDEWALK" DETAIL SHEET 12
- ⑥ DETECTABLE WARNING SURFACE
SEE "DETECTABLE WARNING SURFACE (DWS)" DETAIL SHEET 11
- ⑦ CURB WALL OR CHEEK WALL AS DICTATED BY FIELD
CONDITIONS. SEE "EXISTING ADJACENT SURFACE TRANSITION"
DETAIL SHEET 13
- ⑧ CLEAR SPACE - WIDTH OF CURB RAMP AND EXTENDING 4'
MINIMUM
- ⑨ 3/4" CHAMFER EDGE

 PAY LIMITS FOR CURB RAMPS
(EXCLUDING DWS)

NOT TO SCALE

WEST VIRGINIA DEPARTMENT OF TRANSPORTATION
DIVISION OF HIGHWAYS
STANDARD DETAIL

PREPARED	1-1-1999
REVISION DATE	7/21/10
	10/22/13
	10/01/20

SIDEWALK RAMPS
(Sheet 1 of 13)
TYPE I RAMP

STANDARD SHEET PVT 7

NOTES

THE TYPE OF RAMP TO BE USED SHALL BE AS SPECIFIED ON THE PLANS. THESE STANDARDS CAN BE CONSIDERED GUIDELINES IN SELECTING RAMP TYPES, HOWEVER THEY CAN BE DEVIATED FROM WITH A SPECIAL DETAIL AS NOTED IN PLANS.

RAMP CONCRETE SHALL MEET THE REQUIREMENTS OF SECTION 609 OF THE CURRENT WVDOT, DOH STANDARD SPECIFICATIONS ROADS AND BRIDGES AND ANY SUBSEQUENT DOH SUPPLEMENTAL SPECIFICATIONS, AND THE PUBLIC RIGHTS OF WAY ACCESSIBILITY GUIDELINES (PROWAG) DATED JULY 26, 2011. RAMP SURFACE SHALL INCLUDE A "DETECTABLE WARNING SURFACE" (SEE PVT7 SHT. 11 OF 13) AS SHOWN FOR EACH RAMP TYPE. A COARSE BROOM FINISH, TRANSVERSE TO FLARE SLOPES, OR EQUAL NON-SKID FINISH SHALL BE PROVIDED ON CONCRETE SURFACES.

NORMAL GUTTER FLOW LINE AND PROFILE SHALL BE MAINTAINED THROUGH THE RAMP AREA, UNLESS OTHERWISE SHOWN OR SPECIFIED. POSITIVE DRAINAGE MUST BE MAINTAINED SO THAT NO PONDING OCCURS WITHIN THE RAMP OR CLEAR SPACE AREA.

1/4" MINIMUM, 1/2" MAXIMUM PREFORMED EXPANSION JOINT FILLER, MEETING THE REQUIREMENTS OF SECTION 609 OF THE SPECIFICATIONS, AS NOTED ABOVE, SHALL BE PLACED AT ALL LOCATIONS WHERE RAMP CONTACTS CURB, GUTTER, CONCRETE PAVEMENT, OR OTHER RIGID OBJECTS.

WHERE EXISTING SIDEWALK CONNECTS TO PROPOSED SIDEWALK OR RAMPS, EXPANSION JOINTS ALONG WITH DOWEL BARS WILL BE PLACED. DOWEL BARS WILL BE UTILIZED BETWEEN EXISTING AND PROPOSED TO REDUCE VERTICAL CHANGE. SEE SHEET 11 FOR ADDITIONAL INFORMATION.

SAWCUTS WILL BE UTILIZED DURING DEMOLITION OF EXISTING SIDEWALKS. SIMILAR METHODS MAY BE USED UPON APPROVAL BY FIELD ENGINEER.

RAMPS SHALL NOT BE PLACED IN LINE WITH DRAINAGE STRUCTURES. LOCATION OF THE RAMP SHALL TAKE PRECEDENCE OVER LOCATION OF THE DRAINAGE STRUCTURE, EXCEPT WHERE EXISTING STRUCTURES ARE BEING UTILIZED FOR CONSTRUCTION OF NEW RAMPS.

ANY GRATE IN PEDESTRIAN AREAS SHALL HAVE OPENINGS NOT GREATER THAN 1/2" AND SHALL BE PLACED WITH LONG DIMENSION OF OPENING PERPENDICULAR TO THE DIRECTION OF PEDESTRIAN TRAVEL.

IF THE 8.33% (12:1) SLOPE CANNOT BE OBTAINED DUE TO GRADE OF THE ADJACENT ROADWAY, THE SLOPED PORTION OF THE RAMP SHALL BE EXTENDED TO A MINIMUM LENGTH OF 15'-0".

EXISTING CROSS WALK AND STOP BAR MARKINGS TO BE ERADICATED AND RELOCATED AS DICTATED BY PROPOSED RAMP LOCATIONS. COST NOT INCIDENTAL TO COST OF PROPOSED RAMP.

CURB RAMP WIDTH SHALL MATCH SIDEWALK WIDTH PLUS CLEARANCE. TYPICAL SIDEWALK WIDTH IS 5' MINIMUM. RAMP WIDTHS LESS THAN 5' REQUIRE DIVISION/DISTRICT ENGINEER APPROVAL. WIDTHS LESS THAN 4' REQUIRE AN EXCEPTION JUSTIFICATION REPORT. SEE SHEET 11 FOR INFORMATION REGARDING RAMP THICKNESS.

GRADE BREAKS SHALL BE PERPENDICULAR TO THE DIRECTION OF THE RAMP RUN. SURFACE SLOPES THAT MEET AT GRADE BREAKS SHALL BE FLUSH.

CLEAR SPACE- BEYOND THE BOTTOM GRADE BREAK, A CLEAR SPACE THE WIDTH OF THE CURB RAMP AND EXTENDING 4' MINIMUM INTO THE ABUTTING ROADWAY SHALL BE PROVIDED WITHIN THE WIDTH OF THE PEDESTRIAN STREET CROSSING AND WHOLLY OUTSIDE THE PARALLEL TRAVEL LANE. SURFACE TO MATCH EXISTING. ANY CLEAR SPACE WORK TO BE COMPLETED WILL BE INCIDENTAL TO THE COST OF THE RAMP.

ALL CURB RAMPS SHALL BE CONSTRUCTED TO PROVIDE ACCESS TO EXISTING OPERABLE PARTS. AN EXAMPLE OF THIS WOULD BE PEDESTRIAN PUSH BUTTONS.

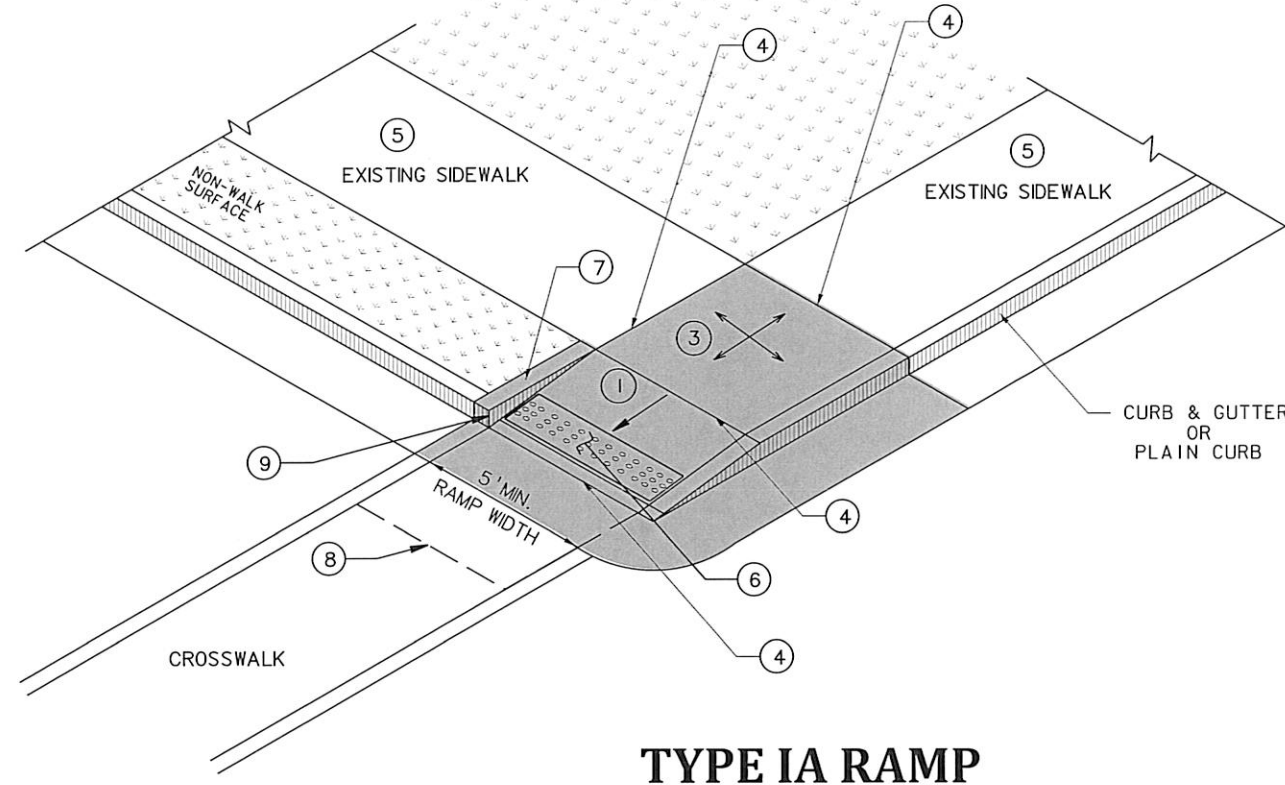

TYPE IA RAMP

LEGEND

- ① 8.33% (12:1) MAXIMUM RAMP SLOPE INCLUDING CONSTRUCTION TOLERANCE SLOPE OF RAMP SHALL CARRY THROUGH TO FACE OF CURB
- ② CROSS SLOPE: 2.00% MAXIMUM INCLUDING CONSTRUCTION TOLERANCE
- ③ CURB RAMPS REQUIRE A (5'-0") MINIMUM TURNING SPACE WHERE PEDESTRIANS PERFORM TURNING MANEUVERS WITH A MAXIMUM CROSS SLOPE OF 2% AND LONGITUDINAL SLOPE MATCHING ROADWAY
- ④ GRADE BREAK REQUIRED TO BE FLUSH (0") AND PERPENDICULAR TO PEDESTRIAN PATH OF TRAVEL
- ⑤ IF SIDEWALK IS EXISTING AND NON-COMPLIANT SEE "TRANSITION TO EXISTING NON-COMPLIANT SIDEWALK" DETAIL SHEET 12
- ⑥ DETECTABLE WARNING SURFACE SEE "DETECTABLE WARNING SURFACE (DWS)" DETAIL SHEET 11
- ⑦ CURB WALL OR CHEEK WALL AS DICTATED BY FIELD CONDITIONS. SEE "EXISTING ADJACENT SURFACE TRANSITION" DETAIL SHEET 13
- ⑧ CLEAR SPACE - WIDTH OF CURB RAMP AND EXTENDING 4' MINIMUM
- ⑨ 3/4" CHAMFER EDGE

PAY LIMITS FOR CURB RAMPS (EXCLUDING DWS)

NOT TO SCALE

WEST VIRGINIA DEPARTMENT OF TRANSPORTATION
DIVISION OF HIGHWAYS
STANDARD DETAIL

PREPARED 1-1-1999

REVISION DATE
7/2/10
10/22/13
10/01/20

SIDEWALK RAMPS
(Sheet 2 of 13)
TYPE IA RAMP

STANDARD SHEET PVT 7

NOTES

THE TYPE OF RAMP TO BE USED SHALL BE AS SPECIFIED ON THE PLANS. THESE STANDARDS CAN BE CONSIDERED GUIDELINES IN SELECTING RAMP TYPES, HOWEVER THEY CAN BE DEVIATED FROM WITH A SPECIAL DETAIL AS NOTED IN PLANS.

RAMP CONCRETE SHALL MEET THE REQUIREMENTS OF SECTION 609 OF THE CURRENT WVDOT, DOH STANDARD SPECIFICATIONS ROADS AND BRIDGES AND ANY SUBSEQUENT DOH SUPPLEMENTAL SPECIFICATIONS, AND THE PUBLIC RIGHTS OF WAY ACCESSIBILITY GUIDELINES (PROWAG) DATED JULY 26, 2011. RAMP SURFACE SHALL INCLUDE A "DETECTABLE WARNING SURFACE" (SEE PVT 7 SHT. 11 OF 13) AS SHOWN FOR EACH RAMP TYPE. A COARSE BROOM FINISH, TRANSVERSE TO FLARE SLOPES, OR EQUAL NON-SKID FINISH SHALL BE PROVIDED ON CONCRETE SURFACES.

NORMAL GUTTER FLOW LINE AND PROFILE SHALL BE MAINTAINED THROUGH THE RAMP AREA, UNLESS OTHERWISE SHOWN OR SPECIFIED. POSITIVE DRAINAGE MUST BE MAINTAINED SO THAT NO PONDING OCCURS WITHIN THE RAMP OR CLEAR SPACE AREA.

1/4" MINIMUM, 1/2" MAXIMUM PREFORMED EXPANSION JOINT FILLER, MEETING THE REQUIREMENTS OF SECTION 609 OF THE SPECIFICATIONS, AS NOTED ABOVE, SHALL BE PLACED AT ALL LOCATIONS WHERE RAMP CONTACTS CURB, GUTTER, CONCRETE PAVEMENT, OR OTHER RIGID OBJECTS.

WHERE EXISTING SIDEWALK CONNECTS TO PROPOSED SIDEWALK OR RAMPS, EXPANSION JOINTS ALONG WITH DOWEL BARS WILL BE PLACED. DOWEL BARS WILL BE UTILIZED BETWEEN EXISTING AND PROPOSED TO REDUCE VERTICAL CHANGE. SEE SHEET 11 FOR ADDITIONAL INFORMATION.

SAWCUTS WILL BE UTILIZED DURING DEMOLITION OF EXISTING SIDEWALKS. SIMILAR METHODS MAY BE USED UPON APPROVAL BY FIELD ENGINEER.

RAMPS SHALL NOT BE PLACED IN LINE WITH DRAINAGE STRUCTURES. LOCATION OF THE RAMP SHALL TAKE PRECEDENCE OVER LOCATION OF THE DRAINAGE STRUCTURE, EXCEPT WHERE EXISTING STRUCTURES ARE BEING UTILIZED FOR CONSTRUCTION OF NEW RAMPS.

ANY GRATE IN PEDESTRIAN AREAS SHALL HAVE OPENINGS NOT GREATER THAN 1/2" AND SHALL BE PLACED WITH LONG DIMENSION OF OPENING PERPENDICULAR TO THE DIRECTION OF PEDESTRIAN TRAVEL.

IF THE 8.33% (12:1) SLOPE CANNOT BE OBTAINED DUE TO GRADE OF THE ADJACENT ROADWAY, THE SLOPED PORTION OF THE RAMP SHALL BE EXTENDED TO A MINIMUM LENGTH OF 15'-0".

EXISTING CROSS WALK AND STOP BAR MARKINGS TO BE ERADICATED AND RELOCATED AS DICTATED BY PROPOSED RAMP LOCATIONS. COST NOT INCIDENTAL TO COST OF PROPOSED RAMP.

CURB RAMP WIDTH SHALL MATCH SIDEWALK WIDTH PLUS CLEARANCE. TYPICAL SIDEWALK WIDTH IS 5' MINIMUM. RAMP WIDTHS LESS THAN 5' REQUIRE DIVISION/DISTRICT ENGINEER APPROVAL. WIDTHS LESS THAN 4' REQUIRE AN EXCEPTION JUSTIFICATION REPORT. SEE SHEET 11 FOR INFORMATION REGARDING RAMP THICKNESS.

GRADE BREAKS SHALL BE PERPENDICULAR TO THE DIRECTION OF THE RAMP RUN. SURFACE SLOPES THAT MEET AT GRADE BREAKS SHALL BE FLUSH.

CLEAR SPACE- BEYOND THE BOTTOM GRADE BREAK, A CLEAR SPACE THE WIDTH OF THE CURB RAMP AND EXTENDING 4' MINIMUM INTO THE ABUTTING ROADWAY SHALL BE PROVIDED WITHIN THE WIDTH OF THE PEDESTRIAN STREET CROSSING AND WHOLLY OUTSIDE THE PARALLEL TRAVEL LANE. SURFACE TO MATCH EXISTING. ANY CLEAR SPACE WORK TO BE COMPLETED WILL BE INCIDENTAL TO THE COST OF THE RAMP.

ALL CURB RAMPS SHALL BE CONSTRUCTED TO PROVIDE ACCESS TO EXISTING OPERABLE PARTS. AN EXAMPLE OF THIS WOULD BE PEDESTRIAN PUSH BUTTONS.

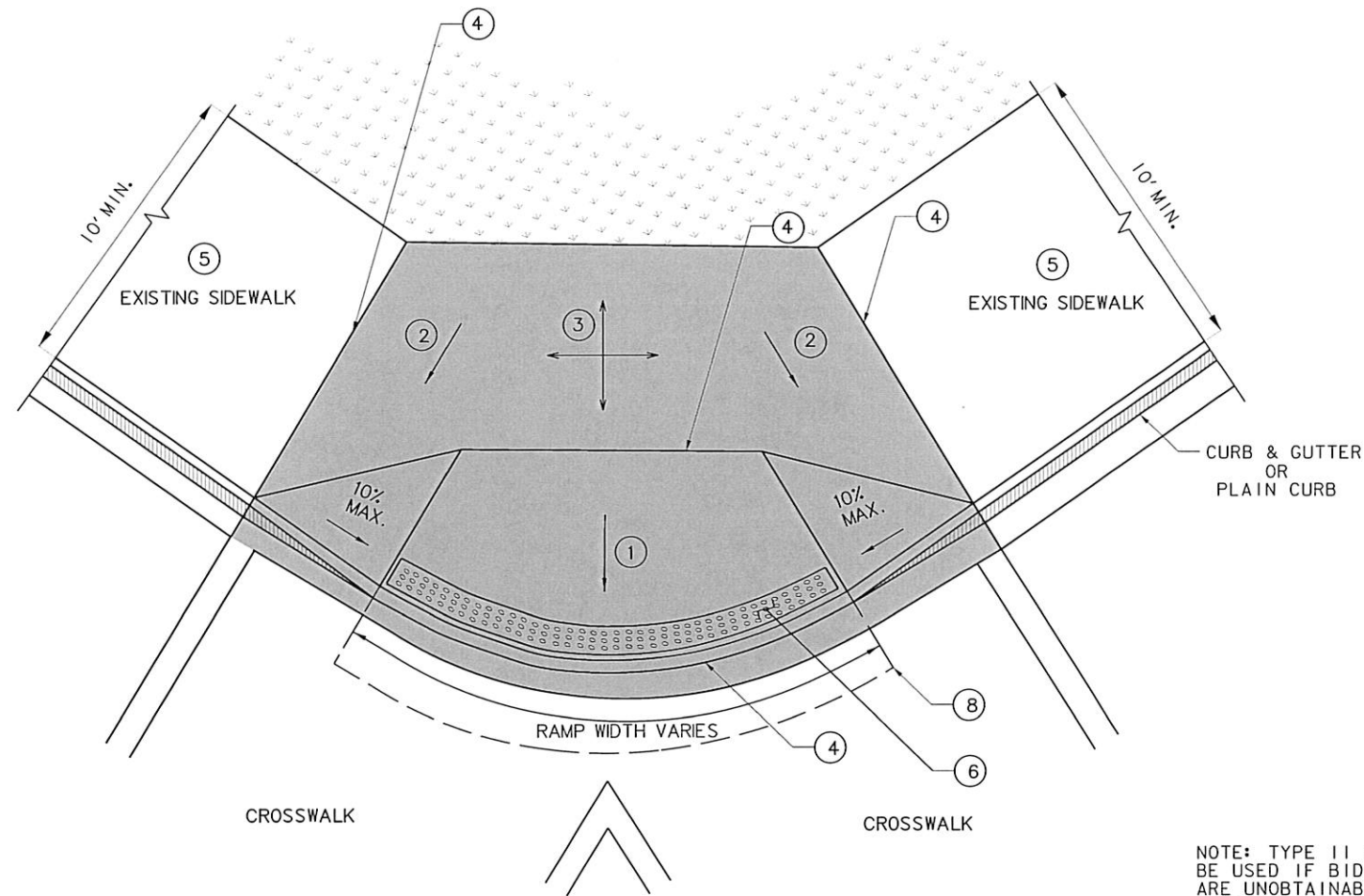

TYPE II RAMP

NOTE: TYPE II RAMPS ARE ONLY TO BE USED IF BIDIRECTIONAL RAMPS ARE UNOBTAINABLE DUE TO PHYSICAL CONSTRAINTS AND THE PEDESTRIAN ACCESS ROUTE (PAR) IS GREATER THAN (>) 10' WIDE FROM BACK OF CURB TO BACK OF SIDEWALK.

LEGEND

- ① 8.33% (12:1) MAXIMUM RAMP SLOPE INCLUDING CONSTRUCTION TOLERANCE SLOPE OF RAMP SHALL CARRY THROUGH TO FACE OF CURB
- ② CROSS SLOPE: 2.00% MAXIMUM INCLUDING CONSTRUCTION TOLERANCE
- ③ CURB RAMPS REQUIRE A (5'-0") MINIMUM TURNING SPACE WHERE PEDESTRIANS PERFORM TURNING MANEUVERS WITH A MAXIMUM CROSS SLOPE OF 2% AND LONGITUDINAL SLOPE MATCHING ROADWAY
- ④ GRADE BREAK REQUIRED TO BE FLUSH (0") AND PERPENDICULAR TO PEDESTRIAN PATH OF TRAVEL
- ⑤ IF SIDEWALK IS EXISTING AND NON-COMPLIANT SEE "TRANSITION TO EXISTING NON-COMPLIANT SIDEWALK" DETAIL SHEET 12
- ⑥ DETECTABLE WARNING SURFACE SEE "DETECTABLE WARNING SURFACE (DWS)" DETAIL SHEET 11
- ⑦ CURB WALL OR CHEEK WALL AS DICTATED BY FIELD CONDITIONS. SEE "EXISTING ADJACENT SURFACE TRANSITION" DETAIL SHEET 13
- ⑧ CLEAR SPACE - WIDTH OF CURB RAMP AND EXTENDING 4' MINIMUM
- ⑨ 3/4" CHAMFER EDGE

PAY LIMITS FOR CURB RAMPS (EXCLUDING DWS)

NOT TO SCALE

WEST VIRGINIA DEPARTMENT OF TRANSPORTATION
DIVISION OF HIGHWAYS
STANDARD DETAIL

PREPARED	1-1-1999
REVISION DATE	7/2/10
	10/22/13
	10/01/20

SIDEWALK RAMPS
(Sheet 4 of 13)
TYPE II RAMP

STANDARD SHEET PVT 7

NOTES

THE TYPE OF RAMP TO BE USED SHALL BE AS SPECIFIED ON THE PLANS. THESE STANDARDS CAN BE CONSIDERED GUIDELINES IN SELECTING RAMP TYPES, HOWEVER THEY CAN BE DEVIATED FROM WITH A SPECIAL DETAIL AS NOTED IN PLANS.

RAMP CONCRETE SHALL MEET THE REQUIREMENTS OF SECTION 609 OF THE CURRENT WVDOT, DOH STANDARD SPECIFICATIONS ROADS AND BRIDGES AND ANY SUBSEQUENT DOH SUPPLEMENTAL SPECIFICATIONS, AND THE PUBLIC RIGHTS OF WAY ACCESSIBILITY GUIDELINES (PROWAG) DATED JULY 26, 2011. RAMP SURFACE SHALL INCLUDE A "DETECTABLE WARNING SURFACE" (SEE PVT7 SHT. 11 OF 13) AS SHOWN FOR EACH RAMP TYPE. A COARSE BROOM FINISH, TRANSVERSE TO FLARE SLOPES, OR EQUAL NON-SKID FINISH SHALL BE PROVIDED ON CONCRETE SURFACES.

NORMAL GUTTER FLOW LINE AND PROFILE SHALL BE MAINTAINED THROUGH THE RAMP AREA, UNLESS OTHERWISE SHOWN OR SPECIFIED. POSITIVE DRAINAGE MUST BE MAINTAINED SO THAT NO PONDING OCCURS WITHIN THE RAMP OR CLEAR SPACE AREA.

1/4" MINIMUM, 1/2" MAXIMUM PREFORMED EXPANSION JOINT FILLER, MEETING THE REQUIREMENTS OF SECTION 609 OF THE SPECIFICATIONS, AS NOTED ABOVE, SHALL BE PLACED AT ALL LOCATIONS WHERE RAMP CONTACTS CURB, GUTTER, CONCRETE PAVEMENT, OR OTHER RIGID OBJECTS.

WHERE EXISTING SIDEWALK CONNECTS TO PROPOSED SIDEWALK OR RAMPS, EXPANSION JOINTS ALONG WITH DOWEL BARS WILL BE PLACED. DOWEL BARS WILL BE UTILIZED BETWEEN EXISTING AND PROPOSED TO REDUCE VERTICAL CHANGE. SEE SHEET 11 FOR ADDITIONAL INFORMATION.

SAWCUTS WILL BE UTILIZED DURING DEMOLITION OF EXISTING SIDEWALKS. SIMILAR METHODS MAY BE USED UPON APPROVAL BY FIELD ENGINEER.

RAMPS SHALL NOT BE PLACED IN LINE WITH DRAINAGE STRUCTURES. LOCATION OF THE RAMP SHALL TAKE PRECEDENCE OVER LOCATION OF THE DRAINAGE STRUCTURE, EXCEPT WHERE EXISTING STRUCTURES ARE BEING UTILIZED FOR CONSTRUCTION OF NEW RAMPS.

ANY GRATE IN PEDESTRIAN AREAS SHALL HAVE OPENINGS NOT GREATER THAN 1/2" AND SHALL BE PLACED WITH LONG DIMENSION OF OPENING PERPENDICULAR TO THE DIRECTION OF PEDESTRIAN TRAVEL.

IF THE 8.33% (12:1) SLOPE CANNOT BE OBTAINED DUE TO GRADE OF THE ADJACENT ROADWAY, THE SLOPED PORTION OF THE RAMP SHALL BE EXTENDED TO A MINIMUM LENGTH OF 15'-0".

EXISTING CROSS WALK AND STOP BAR MARKINGS TO BE ERADICATED AND RELOCATED AS DICTATED BY PROPOSED RAMP LOCATIONS. COST NOT INCIDENTAL TO COST OF PROPOSED RAMP.

CURB RAMP WIDTH SHALL MATCH SIDEWALK WIDTH PLUS CLEARANCE. TYPICAL SIDEWALK WIDTH IS 5' MINIMUM. RAMP WIDTHS LESS THAN 5' REQUIRE DIVISION/DISTRICT ENGINEER APPROVAL. WIDTHS LESS THAN 4' REQUIRE AN EXCEPTION JUSTIFICATION REPORT. SEE SHEET 11 FOR INFORMATION REGARDING RAMP THICKNESS.

GRADE BREAKS SHALL BE PERPENDICULAR TO THE DIRECTION OF THE RAMP RUN. SURFACE SLOPES THAT MEET AT GRADE BREAKS SHALL BE FLUSH.

CLEAR SPACE- BEYOND THE BOTTOM GRADE BREAK, A CLEAR SPACE THE WIDTH OF THE CURB RAMP AND EXTENDING 4' MINIMUM INTO THE ABUTTING ROADWAY SHALL BE PROVIDED WITHIN THE WIDTH OF THE PEDESTRIAN STREET CROSSING AND WHOLLY OUTSIDE THE PARALLEL TRAVEL LANE. SURFACE TO MATCH EXISTING. ANY CLEAR SPACE WORK TO BE COMPLETED WILL BE INCIDENTAL TO THE COST OF THE RAMP.

ALL CURB RAMPS SHALL BE CONSTRUCTED TO PROVIDE ACCESS TO EXISTING OPERABLE PARTS. AN EXAMPLE OF THIS WOULD BE PEDESTRIAN PUSH BUTTONS.

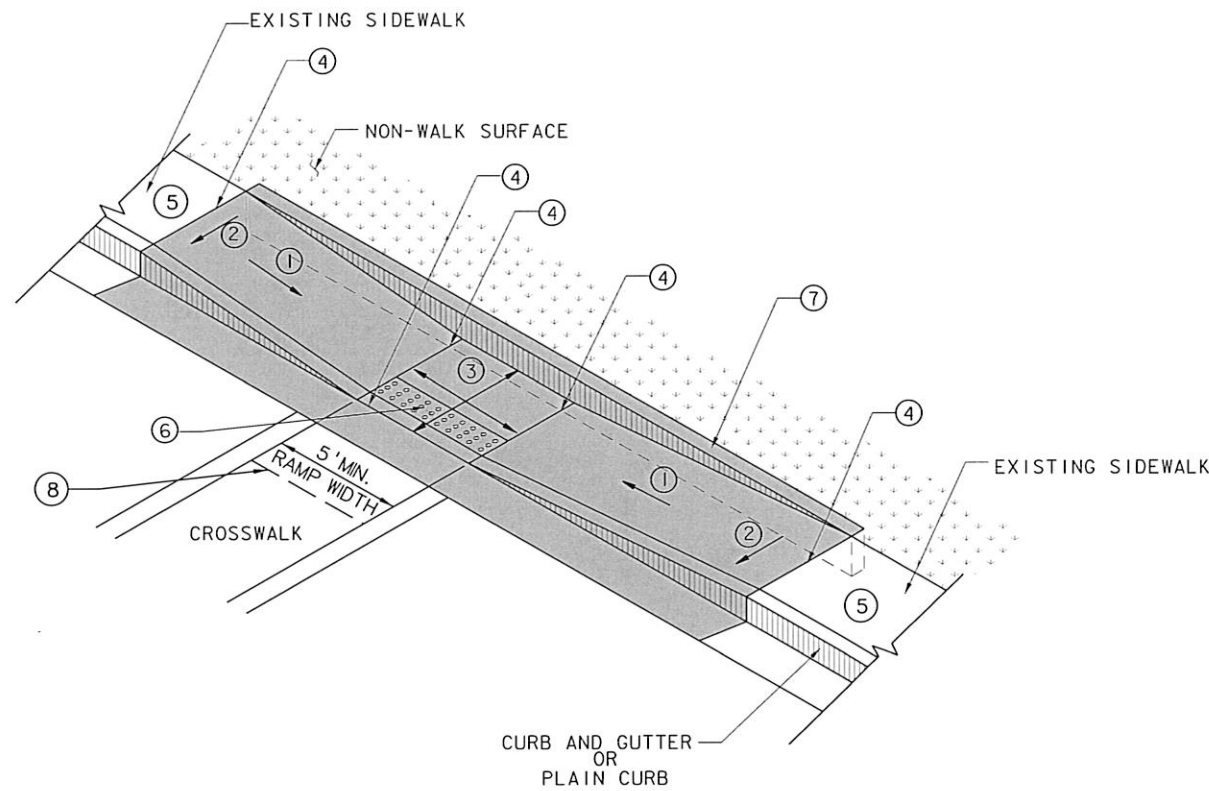

TYPE III RAMP

LEGEND

- ① 8.33% (12:1) MAXIMUM RAMP SLOPE INCLUDING CONSTRUCTION TOLERANCE SLOPE OF RAMP SHALL CARRY THROUGH TO FACE OF CURB
- ② CROSS SLOPE: 2.00% MAXIMUM INCLUDING CONSTRUCTION TOLERANCE
- ③ CURB RAMPS REQUIRE A (5'-0") MINIMUM TURNING SPACE WHERE PEDESTRIANS PERFORM TURNING MANEUVERS WITH A MAXIMUM CROSS SLOPE OF 2% AND LONGITUDINAL SLOPE MATCHING ROADWAY
- ④ GRADE BREAK REQUIRED TO BE FLUSH (0") AND PERPENDICULAR TO PEDESTRIAN PATH OF TRAVEL
- ⑤ IF SIDEWALK IS EXISTING AND NON-COMPLIANT SEE "TRANSITION TO EXISTING NON-COMPLIANT SIDEWALK" DETAIL SHEET 12
- ⑥ DETECTABLE WARNING SURFACE SEE "DETECTABLE WARNING SURFACE (DWS)" DETAIL SHEET 11
- ⑦ CURB WALL OR CHEEK WALL AS DICTATED BY FIELD CONDITIONS. SEE "EXISTING ADJACENT SURFACE TRANSITION" DETAIL SHEET 13
- ⑧ CLEAR SPACE - WIDTH OF CURB RAMP AND EXTENDING 4' MINIMUM
- ⑨ 3/4" CHAMFER EDGE

PAY LIMITS FOR CURB RAMPS (EXCLUDING DWS)

NOT TO SCALE

**WEST VIRGINIA DEPARTMENT OF TRANSPORTATION
DIVISION OF HIGHWAYS
STANDARD DETAIL**

PREPARED 1-1-1999
REVISION DATE
7/21/10
10/22/13
10/01/20

**SIDEWALK RAMPS
(Sheet 5 of 13)
TYPE III RAMP**

STANDARD SHEET PVT 7

NOTES

THE TYPE OF RAMP TO BE USED SHALL BE AS SPECIFIED ON THE PLANS. THESE STANDARDS CAN BE CONSIDERED GUIDELINES IN SELECTING RAMP TYPES, HOWEVER THEY CAN BE DEVIATED FROM WITH A SPECIAL DETAIL AS NOTED IN PLANS.

RAMP CONCRETE SHALL MEET THE REQUIREMENTS OF SECTION 609 OF THE CURRENT WVDOT, DOH STANDARD SPECIFICATIONS ROADS AND BRIDGES AND ANY SUBSEQUENT DOH SUPPLEMENTAL SPECIFICATIONS, AND THE PUBLIC RIGHTS OF WAY ACCESSIBILITY GUIDELINES (PROWAG) DATED JULY 26, 2011. RAMP SURFACE SHALL INCLUDE A "DETECTABLE WARNING SURFACE" (SEE PVT7 SHT. 11 OF 13) AS SHOWN FOR EACH RAMP TYPE. A COARSE BROOM FINISH, TRANSVERSE TO FLARE SLOPES, OR EQUAL NON-SKID FINISH SHALL BE PROVIDED ON CONCRETE SURFACES.

NORMAL GUTTER FLOW LINE AND PROFILE SHALL BE MAINTAINED THROUGH THE RAMP AREA, UNLESS OTHERWISE SHOWN OR SPECIFIED. POSITIVE DRAINAGE MUST BE MAINTAINED SO THAT NO PONDING OCCURS WITHIN THE RAMP OR CLEAR SPACE AREA.

1/4" MINIMUM, 1/2" MAXIMUM PREFORMED EXPANSION JOINT FILLER, MEETING THE REQUIREMENTS OF SECTION 609 OF THE SPECIFICATIONS, AS NOTED ABOVE, SHALL BE PLACED AT ALL LOCATIONS WHERE RAMP CONTACTS CURB, GUTTER, CONCRETE PAVEMENT, OR OTHER RIGID OBJECTS.

WHERE EXISTING SIDEWALK CONNECTS TO PROPOSED SIDEWALK OR RAMPS, EXPANSION JOINTS ALONG WITH DOWEL BARS WILL BE PLACED. DOWEL BARS WILL BE UTILIZED BETWEEN EXISTING AND PROPOSED TO REDUCE VERTICAL CHANGE. SEE SHEET 11 FOR ADDITIONAL INFORMATION.

SAWCUTS WILL BE UTILIZED DURING DEMOLITION OF EXISTING SIDEWALKS. SIMILAR METHODS MAY BE USED UPON APPROVAL BY FIELD ENGINEER.

RAMPS SHALL NOT BE PLACED IN LINE WITH DRAINAGE STRUCTURES. LOCATION OF THE RAMP SHALL TAKE PRECEDENCE OVER LOCATION OF THE DRAINAGE STRUCTURE, EXCEPT WHERE EXISTING STRUCTURES ARE BEING UTILIZED FOR CONSTRUCTION OF NEW RAMPS.

ANY GRATE IN PEDESTRIAN AREAS SHALL HAVE OPENINGS NOT GREATER THAN 1/2" AND SHALL BE PLACED WITH LONG DIMENSION OF OPENING PERPENDICULAR TO THE DIRECTION OF PEDESTRIAN TRAVEL.

IF THE 8.33% (12:1) SLOPE CANNOT BE OBTAINED DUE TO GRADE OF THE ADJACENT ROADWAY, THE SLOPED PORTION OF THE RAMP SHALL BE EXTENDED TO A MINIMUM LENGTH OF 15'-0".

EXISTING CROSS WALK AND STOP BAR MARKINGS TO BE ERADICATED AND RELOCATED AS DICTATED BY PROPOSED RAMP LOCATIONS. COST NOT INCIDENTAL TO COST OF PROPOSED RAMP.

CURB RAMP WIDTH SHALL MATCH SIDEWALK WIDTH PLUS CLEARANCE. TYPICAL SIDEWALK WIDTH IS 5' MINIMUM. RAMP WIDTHS LESS THAN 5' REQUIRE DIVISION/DISTRICT ENGINEER APPROVAL. WIDTHS LESS THAN 4' REQUIRE AN EXCEPTION JUSTIFICATION REPORT. SEE SHEET 11 FOR INFORMATION REGARDING RAMP THICKNESS.

GRADE BREAKS SHALL BE PERPENDICULAR TO THE DIRECTION OF THE RAMP RUN. SURFACE SLOPES THAT MEET AT GRADE BREAKS SHALL BE FLUSH.

CLEAR SPACE- BEYOND THE BOTTOM GRADE BREAK, A CLEAR SPACE THE WIDTH OF THE CURB RAMP AND EXTENDING 4' MINIMUM INTO THE ABUTTING ROADWAY SHALL BE PROVIDED WITHIN THE WIDTH OF THE PEDESTRIAN STREET CROSSING AND WHOLLY OUTSIDE THE PARALLEL TRAVEL LANE. SURFACE TO MATCH EXISTING. ANY CLEAR SPACE WORK TO BE COMPLETED WILL BE INCIDENTAL TO THE COST OF THE RAMP.

ALL CURB RAMPS SHALL BE CONSTRUCTED TO PROVIDE ACCESS TO EXISTING OPERABLE PARTS. AN EXAMPLE OF THIS WOULD BE PEDESTRIAN PUSH BUTTONS.

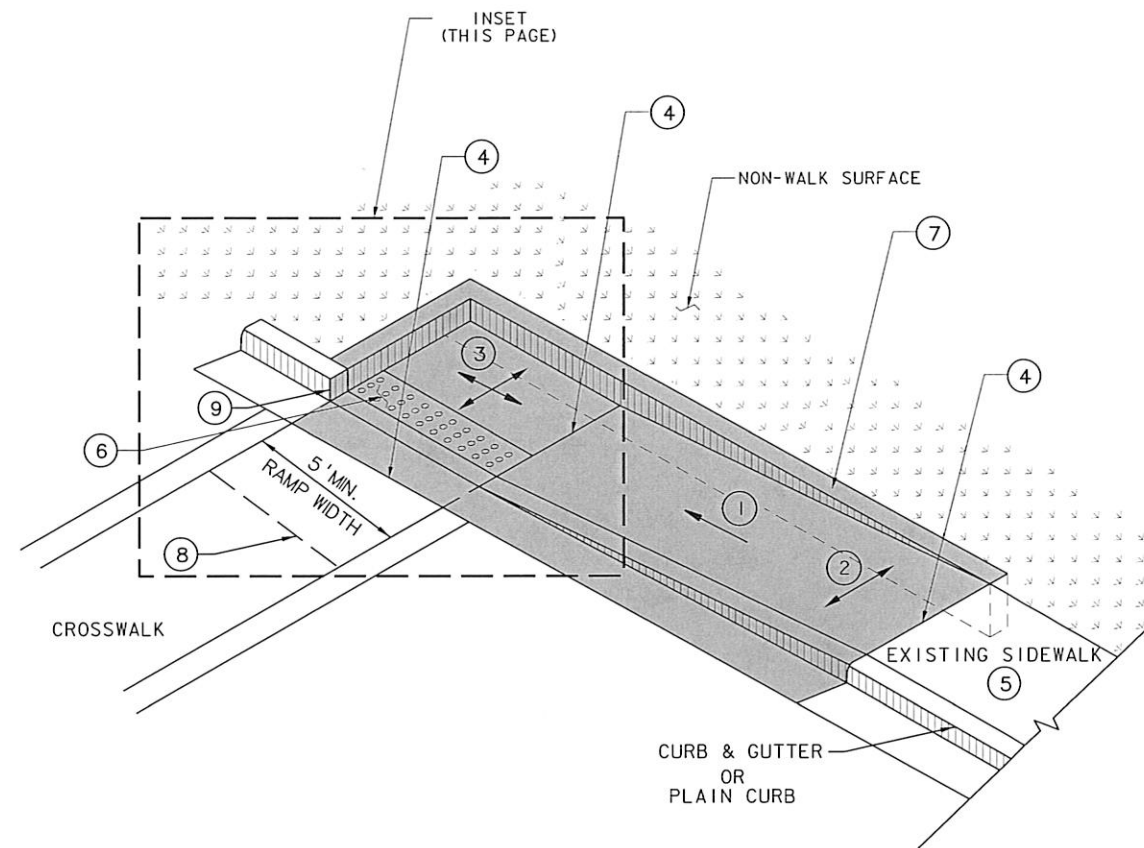

TYPE IIIA - OPTION 1

END OF SIDEWALK
PREFERRED OPTION

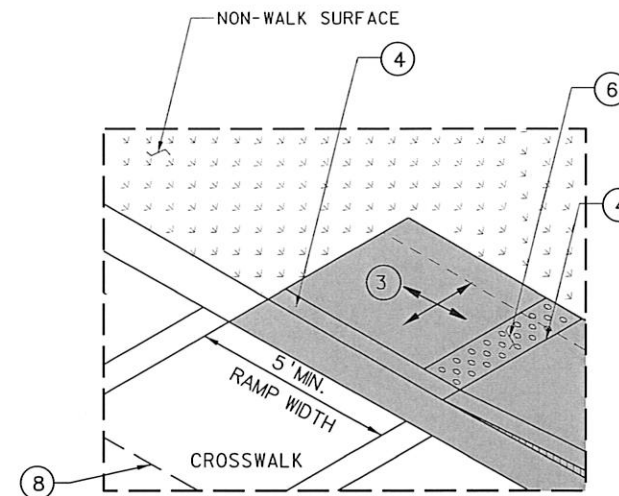

TYPE IIIA - OPTION 2

END OF SIDEWALK
ALTERNATE OPTION
(WITHOUT CURB OR
CHEEK WALL)

LEGEND

- ① 8.33% (12:1) MAXIMUM RAMP SLOPE INCLUDING CONSTRUCTION TOLERANCE
SLOPE OF RAMP SHALL CARRY THROUGH TO FACE OF CURB
- ② CROSS SLOPE: 2.00% MAXIMUM INCLUDING CONSTRUCTION TOLERANCE
- ③ CURB RAMPS REQUIRE A (5'-0") MINIMUM TURNING SPACE WHERE PEDESTRIANS
PERFORM TURNING MANEUVERS WITH A MAXIMUM CROSS SLOPE OF 2% AND
LONGITUDINAL SLOPE MATCHING ROADWAY
- ④ GRADE BREAK REQUIRED TO BE FLUSH (0") AND PERPENDICULAR TO
PEDESTRIAN PATH OF TRAVEL
- ⑤ IF SIDEWALK IS EXISTING AND NON-COMPLIANT SEE "TRANSITION
TO EXISTING NON-COMPLIANT SIDEWALK" DETAIL SHEET 12
- ⑥ DETECTABLE WARNING SURFACE
SEE "DETECTABLE WARNING SURFACE (DWS)" DETAIL SHEET 11
- ⑦ CURB WALL OR CHEEK WALL AS DICTATED BY FIELD
CONDITIONS. SEE "EXISTING ADJACENT SURFACE TRANSITION"
DETAIL SHEET 13
- ⑧ CLEAR SPACE - WIDTH OF CURB RAMP AND EXTENDING 4'
MINIMUM
- ⑨ 3/4" CHAMFER EDGE



PAY LIMITS FOR CURB RAMPS
(EXCLUDING DWS)

NOT TO SCALE

SHEET 1 OF 2

WEST VIRGINIA DEPARTMENT OF TRANSPORTATION
DIVISION OF HIGHWAYS
STANDARD DETAIL

PREPARED 1-1-1999
REVISION DATE
7/21/10
10/22/13
10/01/20

SIDEWALK RAMPS
(Sheet 6 of 13)
TYPE IIIA RAMP

STANDARD SHEET PVT 7

NOTES

THE TYPE OF RAMP TO BE USED SHALL BE AS SPECIFIED ON THE PLANS. THESE STANDARDS CAN BE CONSIDERED GUIDELINES IN SELECTING RAMP TYPES, HOWEVER THEY CAN BE DEVIATED FROM WITH A SPECIAL DETAIL AS NOTED IN PLANS.

RAMP CONCRETE SHALL MEET THE REQUIREMENTS OF SECTION 609 OF THE CURRENT WVDOT, DOH STANDARD SPECIFICATIONS ROADS AND BRIDGES AND ANY SUBSEQUENT DOH SUPPLEMENTAL SPECIFICATIONS, AND THE PUBLIC RIGHTS OF WAY ACCESSIBILITY GUIDELINES (PROWAG) DATED JULY 26, 2011. RAMP SURFACE SHALL INCLUDE A "DETECTABLE WARNING SURFACE" (SEE PVT7 SHT. 11 OF 13) AS SHOWN FOR EACH RAMP TYPE. A COARSE BROOM FINISH, TRANSVERSE TO FLARE SLOPES, OR EQUAL NON-SKID FINISH SHALL BE PROVIDED ON CONCRETE SURFACES.

NORMAL GUTTER FLOW LINE AND PROFILE SHALL BE MAINTAINED THROUGH THE RAMP AREA, UNLESS OTHERWISE SHOWN OR SPECIFIED. POSITIVE DRAINAGE MUST BE MAINTAINED SO THAT NO PONDING OCCURS WITHIN THE RAMP OR CLEAR SPACE AREA.

1/4" MINIMUM, 1/2" MAXIMUM PREFORMED EXPANSION JOINT FILLER, MEETING THE REQUIREMENTS OF SECTION 609 OF THE SPECIFICATIONS, AS NOTED ABOVE, SHALL BE PLACED AT ALL LOCATIONS WHERE RAMP CONTACTS CURB, GUTTER, CONCRETE PAVEMENT, OR OTHER RIGID OBJECTS.

WHERE EXISTING SIDEWALK CONNECTS TO PROPOSED SIDEWALK OR RAMPS, EXPANSION JOINTS ALONG WITH DOWEL BARS WILL BE PLACED. DOWEL BARS WILL BE UTILIZED BETWEEN EXISTING AND PROPOSED TO REDUCE VERTICAL CHANGE. SEE SHEET 11 FOR ADDITIONAL INFORMATION.

SAWCUTS WILL BE UTILIZED DURING DEMOLITION OF EXISTING SIDEWALKS. SIMILAR METHODS MAY BE USED UPON APPROVAL BY FIELD ENGINEER.

RAMPS SHALL NOT BE PLACED IN LINE WITH DRAINAGE STRUCTURES. LOCATION OF THE RAMP SHALL TAKE PRECEDENCE OVER LOCATION OF THE DRAINAGE STRUCTURE, EXCEPT WHERE EXISTING STRUCTURES ARE BEING UTILIZED FOR CONSTRUCTION OF NEW RAMPS.

ANY GRATE IN PEDESTRIAN AREAS SHALL HAVE OPENINGS NOT GREATER THAN 1/2" AND SHALL BE PLACED WITH LONG DIMENSION OF OPENING PERPENDICULAR TO THE DIRECTION OF PEDESTRIAN TRAVEL.

IF THE 8.33% (12:1) SLOPE CANNOT BE OBTAINED DUE TO GRADE OF THE ADJACENT ROADWAY, THE SLOPED PORTION OF THE RAMP SHALL BE EXTENDED TO A MINIMUM LENGTH OF 15'-0".

EXISTING CROSS WALK AND STOP BAR MARKINGS TO BE ERADICATED AND RELOCATED AS DICTATED BY PROPOSED RAMP LOCATIONS. COST NOT INCIDENTAL TO COST OF PROPOSED RAMP.

CURB RAMP WIDTH SHALL MATCH SIDEWALK WIDTH PLUS CLEARANCE. TYPICAL SIDEWALK WIDTH IS 5' MINIMUM. RAMP WIDTHS LESS THAN 5' REQUIRE DIVISION/DISTRICT ENGINEER APPROVAL. WIDTHS LESS THAN 4' REQUIRE AN EXCEPTION JUSTIFICATION REPORT. SEE SHEET 11 FOR INFORMATION REGARDING RAMP THICKNESS.

GRADE BREAKS SHALL BE PERPENDICULAR TO THE DIRECTION OF THE RAMP RUN. SURFACE SLOPES THAT MEET AT GRADE BREAKS SHALL BE FLUSH.

CLEAR SPACE- BEYOND THE BOTTOM GRADE BREAK, A CLEAR SPACE THE WIDTH OF THE CURB RAMP AND EXTENDING 4' MINIMUM INTO THE ABUTTING ROADWAY SHALL BE PROVIDED WITHIN THE WIDTH OF THE PEDESTRIAN STREET CROSSING AND WHOLLY OUTSIDE THE PARALLEL TRAVEL LANE. SURFACE TO MATCH EXISTING. ANY CLEAR SPACE WORK TO BE COMPLETED WILL BE INCIDENTAL TO THE COST OF THE RAMP.

ALL CURB RAMPS SHALL BE CONSTRUCTED TO PROVIDE ACCESS TO EXISTING OPERABLE PARTS. AN EXAMPLE OF THIS WOULD BE PEDESTRIAN PUSH BUTTONS.

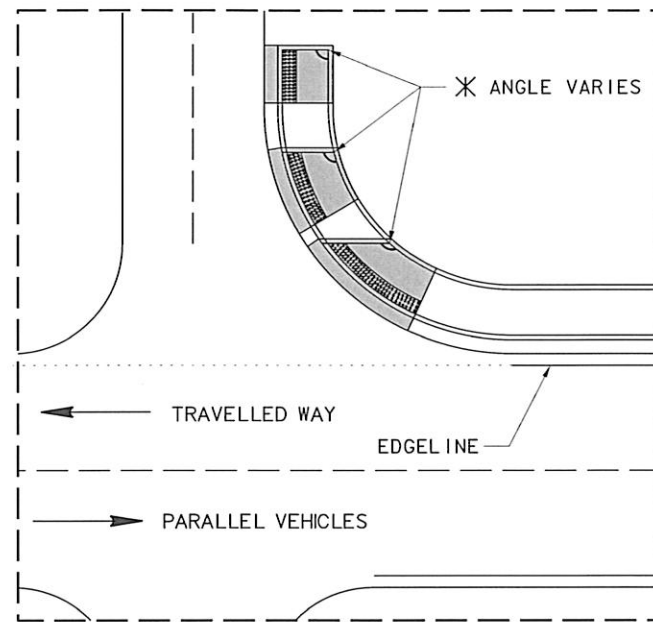

* LOCATIONS NOTED ARE EXAMPLES ONLY. CURB RAMP CAN BE LOCATED AT ANY POINT ALONG RADIUS OF SIDEWALK AS DETERMINED BY FIELD CONDITIONS. WIDTH AT CURB DEPENDENT ON ANGLE.

TYPE IIIA - OPTION 3

EXAMPLE OF RAMP LOCATION ALONG RADIUS

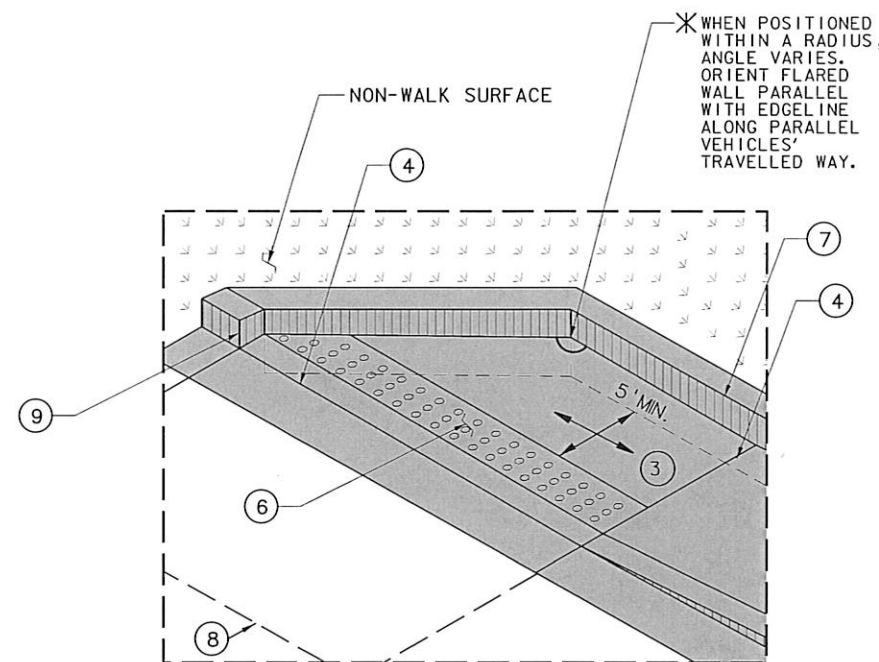

TYPE IIIA - OPTION 3

END OF SIDEWALK
PREFERRED OPTION
(LARGER CURB ANGLE)

LEGEND

- ① 8.33% (12:1) MAXIMUM RAMP SLOPE INCLUDING CONSTRUCTION TOLERANCE SLOPE OF RAMP SHALL CARRY THROUGH TO FACE OF CURB
- ② CROSS SLOPE: 2.00% MAXIMUM INCLUDING CONSTRUCTION TOLERANCE
- ③ CURB RAMPS REQUIRE A (5'-0") MINIMUM TURNING SPACE WHERE PEDESTRIANS PERFORM TURNING MANEUVERS WITH A MAXIMUM CROSS SLOPE OF 2% AND LONGITUDINAL SLOPE MATCHING ROADWAY
- ④ GRADE BREAK REQUIRED TO BE FLUSH (0") AND PERPENDICULAR TO PEDESTRIAN PATH OF TRAVEL
- ⑤ IF SIDEWALK IS EXISTING AND NON-COMPLIANT SEE "TRANSITION TO EXISTING NON-COMPLIANT SIDEWALK" DETAIL SHEET 12
- ⑥ DETECTABLE WARNING SURFACE SEE "DETECTABLE WARNING SURFACE (DWS)" DETAIL SHEET 11
- ⑦ CURB WALL OR CHEEK WALL AS DICTATED BY FIELD CONDITIONS. SEE "EXISTING ADJACENT SURFACE TRANSITION" DETAIL SHEET 13
- ⑧ CLEAR SPACE - WIDTH OF CURB RAMP AND EXTENDING 4' MINIMUM
- ⑨ 3/4" CHAMFER EDGE



PAY LIMITS FOR CURB RAMPS
(EXCLUDING DWS)

NOT TO SCALE

SHEET 2 OF 2

WEST VIRGINIA DEPARTMENT OF TRANSPORTATION
DIVISION OF HIGHWAYS
STANDARD DETAIL

PREPARED	1-1-1999
REVISION DATE	7/21/10
	10/22/13
	10/01/20

SIDEWALK RAMPS
(Sheet 7 of 13)
TYPE IIIA RAMP

STANDARD SHEET PVT 7

NOTES

THE TYPE OF RAMP TO BE USED SHALL BE AS SPECIFIED ON THE PLANS. THESE STANDARDS CAN BE CONSIDERED GUIDELINES IN SELECTING RAMP TYPES, HOWEVER THEY CAN BE DEVIATED FROM WITH A SPECIAL DETAIL AS NOTED IN PLANS.

RAMP CONCRETE SHALL MEET THE REQUIREMENTS OF SECTION 609 OF THE CURRENT WVDOT, DOH STANDARD SPECIFICATIONS ROADS AND BRIDGES AND ANY SUBSEQUENT DOH SUPPLEMENTAL SPECIFICATIONS, AND THE PUBLIC RIGHTS OF WAY ACCESSIBILITY GUIDELINES (PROWAG) DATED JULY 26, 2011. RAMP SURFACE SHALL INCLUDE A "DETECTABLE WARNING SURFACE" (SEE PVT 7 SHT. 11 OF 13) AS SHOWN FOR EACH RAMP TYPE. A COARSE BROOM FINISH, TRANSVERSE TO FLARE SLOPES, OR EQUAL NON-SKID FINISH SHALL BE PROVIDED ON CONCRETE SURFACES.

NORMAL GUTTER FLOW LINE AND PROFILE SHALL BE MAINTAINED THROUGH THE RAMP AREA, UNLESS OTHERWISE SHOWN OR SPECIFIED. POSITIVE DRAINAGE MUST BE MAINTAINED SO THAT NO PONDING OCCURS WITHIN THE RAMP OR CLEAR SPACE AREA.

1/4" MINIMUM, 1/2" MAXIMUM PREFORMED EXPANSION JOINT FILLER, MEETING THE REQUIREMENTS OF SECTION 609 OF THE SPECIFICATIONS, AS NOTED ABOVE, SHALL BE PLACED AT ALL LOCATIONS WHERE RAMP CONTACTS CURB, GUTTER, CONCRETE PAVEMENT, OR OTHER RIGID OBJECTS.

WHERE EXISTING SIDEWALK CONNECTS TO PROPOSED SIDEWALK OR RAMPS, EXPANSION JOINTS ALONG WITH DOWEL BARS WILL BE PLACED. DOWEL BARS WILL BE UTILIZED BETWEEN EXISTING AND PROPOSED TO REDUCE VERTICAL CHANGE. SEE SHEET 11 FOR ADDITIONAL INFORMATION.

SAWCUTS WILL BE UTILIZED DURING DEMOLITION OF EXISTING SIDEWALKS. SIMILAR METHODS MAY BE USED UPON APPROVAL BY FIELD ENGINEER.

RAMPS SHALL NOT BE PLACED IN LINE WITH DRAINAGE STRUCTURES. LOCATION OF THE RAMP SHALL TAKE PRECEDENCE OVER LOCATION OF THE DRAINAGE STRUCTURE, EXCEPT WHERE EXISTING STRUCTURES ARE BEING UTILIZED FOR CONSTRUCTION OF NEW RAMPS.

ANY GRATE IN PEDESTRIAN AREAS SHALL HAVE OPENINGS NOT GREATER THAN 1/2" AND SHALL BE PLACED WITH LONG DIMENSION OF OPENING PERPENDICULAR TO THE DIRECTION OF PEDESTRIAN TRAVEL.

IF THE 8.33% (12:1) SLOPE CANNOT BE OBTAINED DUE TO GRADE OF THE ADJACENT ROADWAY, THE SLOPED PORTION OF THE RAMP SHALL BE EXTENDED TO A MINIMUM LENGTH OF 15'-0".

EXISTING CROSS WALK AND STOP BAR MARKINGS TO BE ERADICATED AND RELOCATED AS DICTATED BY PROPOSED RAMP LOCATIONS. COST NOT INCIDENTAL TO COST OF PROPOSED RAMP.

CURB RAMP WIDTH SHALL MATCH SIDEWALK WIDTH PLUS CLEARANCE. TYPICAL SIDEWALK WIDTH IS 5' MINIMUM. RAMP WIDTHS LESS THAN 5' REQUIRE DIVISION/DISTRICT ENGINEER APPROVAL. WIDTHS LESS THAN 4' REQUIRE AN EXCEPTION JUSTIFICATION REPORT. SEE SHEET 11 FOR INFORMATION REGARDING RAMP THICKNESS.

GRADE BREAKS SHALL BE PERPENDICULAR TO THE DIRECTION OF THE RAMP RUN. SURFACE SLOPES THAT MEET AT GRADE BREAKS SHALL BE FLUSH.

CLEAR SPACE- BEYOND THE BOTTOM GRADE BREAK, A CLEAR SPACE THE WIDTH OF THE CURB RAMP AND EXTENDING 4' MINIMUM INTO THE ABUTTING ROADWAY SHALL BE PROVIDED WITHIN THE WIDTH OF THE PEDESTRIAN STREET CROSSING AND WHOLLY OUTSIDE THE PARALLEL TRAVEL LANE. SURFACE TO MATCH EXISTING. ANY CLEAR SPACE WORK TO BE COMPLETED WILL BE INCIDENTAL TO THE COST OF THE RAMP.

ALL CURB RAMPS SHALL BE CONSTRUCTED TO PROVIDE ACCESS TO EXISTING OPERABLE PARTS. AN EXAMPLE OF THIS WOULD BE PEDESTRIAN PUSH BUTTONS.

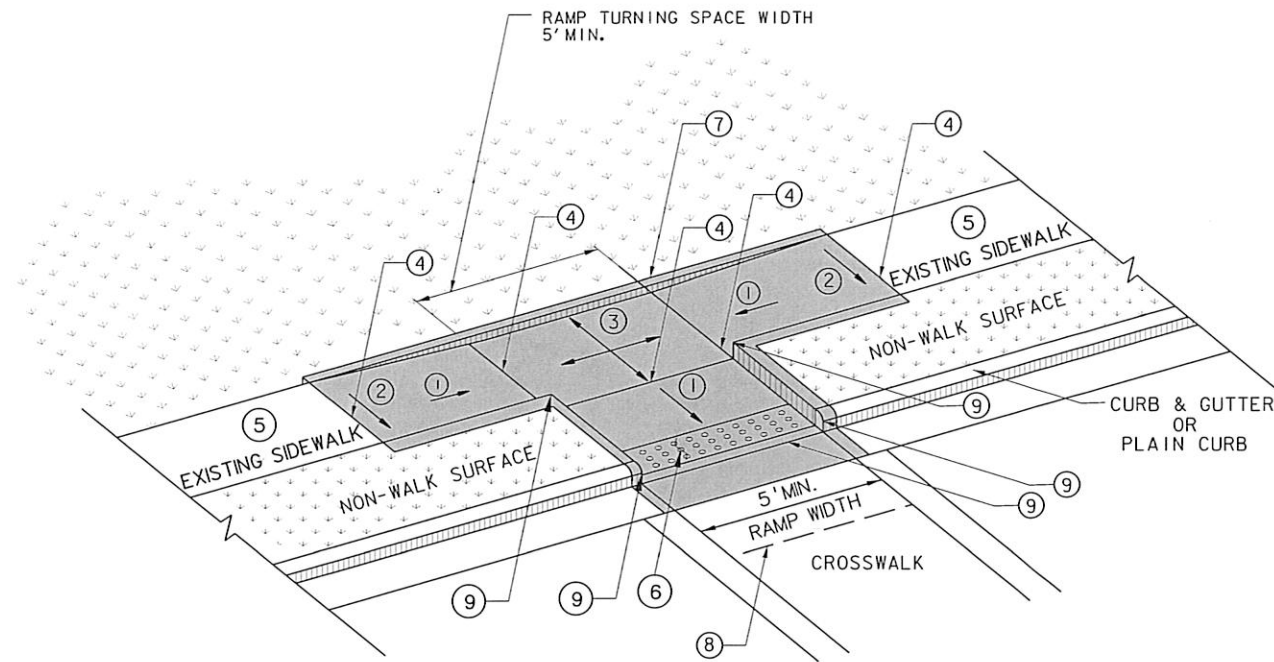

TYPE IV RAMP

LEGEND

- ① 8.33% (12:1) MAXIMUM RAMP SLOPE INCLUDING CONSTRUCTION TOLERANCE SLOPE OF RAMP SHALL CARRY THROUGH TO FACE OF CURB
- ② CROSS SLOPE: 2.00% MAXIMUM INCLUDING CONSTRUCTION TOLERANCE
- ③ CURB RAMPS REQUIRE A (5'-0") MINIMUM TURNING SPACE WHERE PEDESTRIANS PERFORM TURNING MANEUVERS WITH A MAXIMUM CROSS SLOPE OF 2% AND LONGITUDINAL SLOPE MATCHING ROADWAY
- ④ GRADE BREAK REQUIRED TO BE FLUSH (0") AND PERPENDICULAR TO PEDESTRIAN PATH OF TRAVEL
- ⑤ IF SIDEWALK IS EXISTING AND NON-COMPLIANT SEE "TRANSITION TO EXISTING NON-COMPLIANT SIDEWALK" DETAIL SHEET 12
- ⑥ DETECTABLE WARNING SURFACE SEE "DETECTABLE WARNING SURFACE (DWS)" DETAIL SHEET 11
- ⑦ CURB WALL OR CHEEK WALL AS DICTATED BY FIELD CONDITIONS. SEE "EXISTING ADJACENT SURFACE TRANSITION" DETAIL SHEET 13
- ⑧ CLEAR SPACE - WIDTH OF CURB RAMP AND EXTENDING 4' MINIMUM
- ⑨ 3/4" CHAMFER EDGE

PAY LIMITS FOR CURB RAMPS (EXCLUDING DWS)

NOT TO SCALE

WEST VIRGINIA DEPARTMENT OF TRANSPORTATION
DIVISION OF HIGHWAYS
STANDARD DETAIL

PREPARED	1-1-1999
REVISION DATE	7/21/10
	10/22/13
	10/01/20

SIDEWALK RAMPS
(Sheet 9 of 13)
TYPE IV RAMP

STANDARD SHEET PVT 7

NOTES

THE TYPE OF RAMP TO BE USED SHALL BE AS SPECIFIED ON THE PLANS. THESE STANDARDS CAN BE CONSIDERED GUIDELINES IN SELECTING RAMP TYPES, HOWEVER THEY CAN BE DEVIATED FROM WITH A SPECIAL DETAIL AS NOTED IN PLANS.

RAMP CONCRETE SHALL MEET THE REQUIREMENTS OF SECTION 609 OF THE CURRENT WVDOT, DOH STANDARD SPECIFICATIONS ROADS AND BRIDGES AND ANY SUBSEQUENT DOH SUPPLEMENTAL SPECIFICATIONS, AND THE PUBLIC RIGHTS OF WAY ACCESSIBILITY GUIDELINES (PROWAG) DATED JULY 26, 2011. RAMP SURFACE SHALL INCLUDE A "DETECTABLE WARNING SURFACE" (SEE PVT7 SHT. 11 OF 13) AS SHOWN FOR EACH RAMP TYPE. A COARSE BROOM FINISH, TRANSVERSE TO FLARE SLOPES, OR EQUAL NON-SKID FINISH SHALL BE PROVIDED ON CONCRETE SURFACES.

NORMAL GUTTER FLOW LINE AND PROFILE SHALL BE MAINTAINED THROUGH THE RAMP AREA, UNLESS OTHERWISE SHOWN OR SPECIFIED. POSITIVE DRAINAGE MUST BE MAINTAINED SO THAT NO PONDING OCCURS WITHIN THE RAMP OR CLEAR SPACE AREA.

1/4" MINIMUM, 1/2" MAXIMUM PREFORMED EXPANSION JOINT FILLER, MEETING THE REQUIREMENTS OF SECTION 609 OF THE SPECIFICATIONS, AS NOTED ABOVE, SHALL BE PLACED AT ALL LOCATIONS WHERE RAMP CONTACTS CURB, GUTTER, CONCRETE PAVEMENT, OR OTHER RIGID OBJECTS.

WHERE EXISTING SIDEWALK CONNECTS TO PROPOSED SIDEWALK OR RAMPS, EXPANSION JOINTS ALONG WITH DOWEL BARS WILL BE PLACED. DOWEL BARS WILL BE UTILIZED BETWEEN EXISTING AND PROPOSED TO REDUCE VERTICAL CHANGE. SEE SHEET 11 FOR ADDITIONAL INFORMATION.

SAWCUTS WILL BE UTILIZED DURING DEMOLITION OF EXISTING SIDEWALKS. SIMILAR METHODS MAY BE USED UPON APPROVAL BY FIELD ENGINEER.

RAMPS SHALL NOT BE PLACED IN LINE WITH DRAINAGE STRUCTURES. LOCATION OF THE RAMP SHALL TAKE PRECEDENCE OVER LOCATION OF THE DRAINAGE STRUCTURE, EXCEPT WHERE EXISTING STRUCTURES ARE BEING UTILIZED FOR CONSTRUCTION OF NEW RAMPS.

ANY GRATE IN PEDESTRIAN AREAS SHALL HAVE OPENINGS NOT GREATER THAN 1/2" AND SHALL BE PLACED WITH LONG DIMENSION OF OPENING PERPENDICULAR TO THE DIRECTION OF PEDESTRIAN TRAVEL.

IF THE 8.33% (12:1) SLOPE CANNOT BE OBTAINED DUE TO GRADE OF THE ADJACENT ROADWAY, THE SLOPED PORTION OF THE RAMP SHALL BE EXTENDED TO A MINIMUM LENGTH OF 15'-0".

EXISTING CROSS WALK AND STOP BAR MARKINGS TO BE ERADICATED AND RELOCATED AS DICTATED BY PROPOSED RAMP LOCATIONS. COST NOT INCIDENTAL TO COST OF PROPOSED RAMP.

CURB RAMP WIDTH SHALL MATCH SIDEWALK WIDTH PLUS CLEARANCE. TYPICAL SIDEWALK WIDTH IS 5' MINIMUM. RAMP WIDTHS LESS THAN 5' REQUIRE DIVISION/DISTRICT ENGINEER APPROVAL. WIDTHS LESS THAN 4' REQUIRE AN EXCEPTION JUSTIFICATION REPORT. SEE SHEET 11 FOR INFORMATION REGARDING RAMP THICKNESS.

GRADE BREAKS SHALL BE PERPENDICULAR TO THE DIRECTION OF THE RAMP RUN. SURFACE SLOPES THAT MEET AT GRADE BREAKS SHALL BE FLUSH.

CLEAR SPACE- BEYOND THE BOTTOM GRADE BREAK, A CLEAR SPACE THE WIDTH OF THE CURB RAMP AND EXTENDING 4' MINIMUM INTO THE ABUTTING ROADWAY SHALL BE PROVIDED WITHIN THE WIDTH OF THE PEDESTRIAN STREET CROSSING AND WHOLLY OUTSIDE THE PARALLEL TRAVEL LANE. SURFACE TO MATCH EXISTING. ANY CLEAR SPACE WORK TO BE COMPLETED WILL BE INCIDENTAL TO THE COST OF THE RAMP.

ALL CURB RAMPS SHALL BE CONSTRUCTED TO PROVIDE ACCESS TO EXISTING OPERABLE PARTS. AN EXAMPLE OF THIS WOULD BE PEDESTRIAN PUSH BUTTONS.

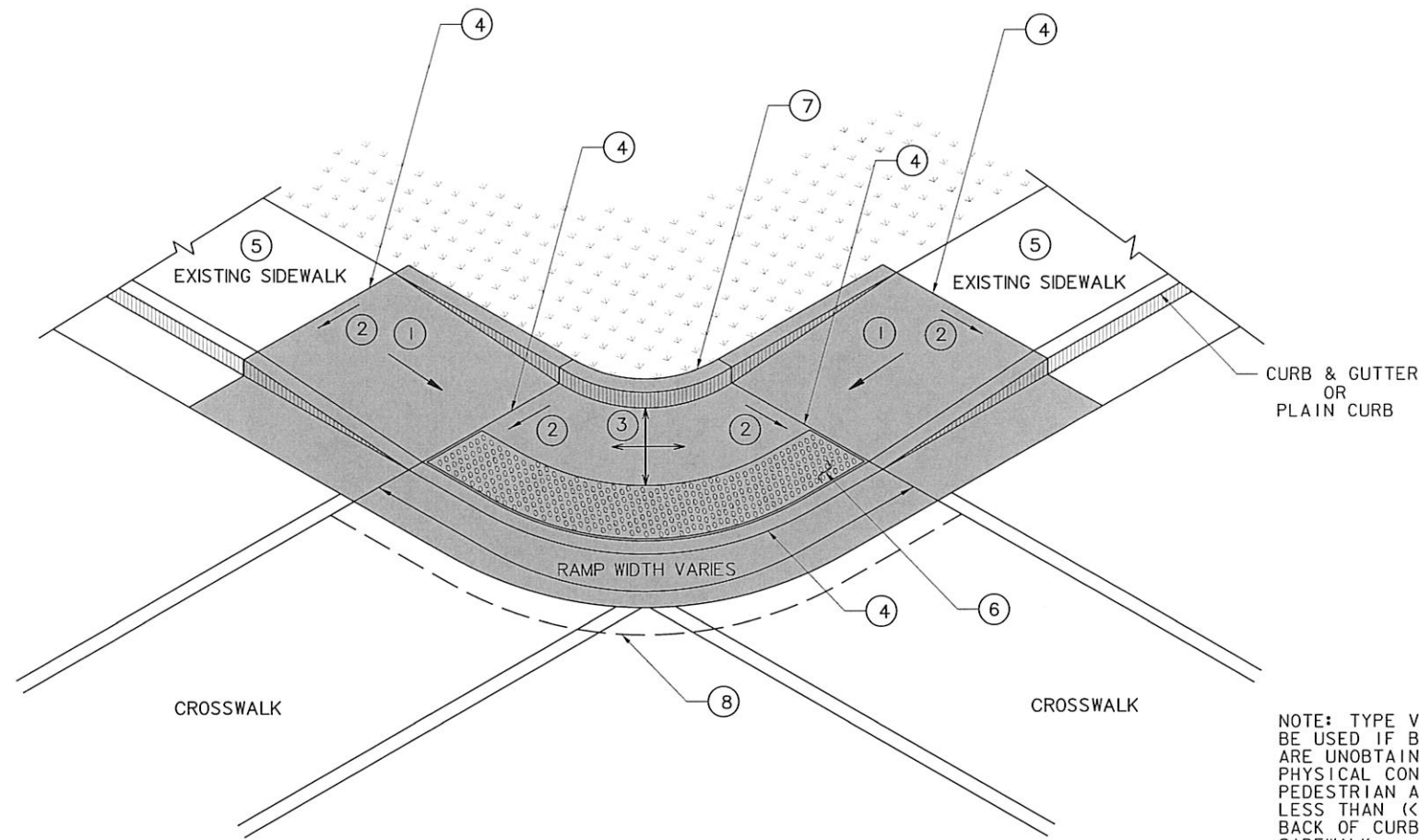

TYPE V
DROP CORNER

LEGEND

- ① 8.33% (12:1) MAXIMUM RAMP SLOPE INCLUDING CONSTRUCTION TOLERANCE
SLOPE OF RAMP SHALL CARRY THROUGH TO FACE OF CURB
- ② CROSS SLOPE: 2.00% MAXIMUM INCLUDING CONSTRUCTION TOLERANCE
- ③ CURB RAMPS REQUIRE A (5'-0") MINIMUM TURNING SPACE WHERE PEDESTRIANS
PERFORM TURNING MANEUVERS WITH A MAXIMUM CROSS SLOPE OF 2% AND
LONGITUDINAL SLOPE MATCHING ROADWAY
- ④ GRADE BREAK REQUIRED TO BE FLUSH (0") AND PERPENDICULAR TO
PEDESTRIAN PATH OF TRAVEL
- ⑤ IF SIDEWALK IS EXISTING AND NON-COMPLIANT SEE "TRANSITION
TO EXISTING NON-COMPLIANT SIDEWALK" DETAIL SHEET 12
- ⑥ DETECTABLE WARNING SURFACE
SEE "DETECTABLE WARNING SURFACE (DWS)" DETAIL SHEET 11
- ⑦ CURB WALL OR CHEEK WALL AS DICTATED BY FIELD
CONDITIONS. SEE "EXISTING ADJACENT SURFACE TRANSITION"
DETAIL SHEET 13
- ⑧ CLEAR SPACE - WIDTH OF CURB RAMP AND EXTENDING 4'
MINIMUM
- ⑨ 3/4" CHAMFER EDGE

PAY LIMITS FOR CURB RAMPS
(EXCLUDING DWS)



NOT TO SCALE

WEST VIRGINIA DEPARTMENT OF TRANSPORTATION
DIVISION OF HIGHWAYS
STANDARD DETAIL

PREPARED 1-1-1999

REVISION DATE
7/21/10
10/22/13
10/01/20

SIDEWALK RAMPS
(Sheet 10 of 13)
TYPE V RAMP

STANDARD SHEET PVT 7



Solicitation: 2026-27 ADA Ramp Installation Project (E6 05/26-163)

GENERAL TERMS AND CONDITIONS

1. CONTRACTUAL AGREEMENT: Issuance of an Award Document signed by the City of Charleston, WV, constitutes acceptance by the City of this Contract made by and between the City of Charleston and the Vendor. Vendor's signature on its bid, or on the Contract if the Contract is not the result of a bid solicitation, signifies Vendor's agreement to be bound by and accept the terms and conditions contained in this Contract. The plans, specifications, and other specified provisions thereto and Vendor's response thereto, including but not limited to specifications, warranty information, any addendums, and all other information provided by Vendor, are incorporated herein and made a part hereof, collectively, as "Attachment A."

In consideration of such payments and for other good and valuable consideration, the receipt and sufficiency of which are hereby acknowledged, Vendor agrees to provide the Materials and perform the Services in accordance with the provisions of this Agreement, Attachment A, and all other exhibits attached hereto and documents incorporated herein by reference.

The parties acknowledge and agree that Attachment A is intended to and shall supplement the terms of this Agreement, but in the event of any inconsistency between the provisions of this Agreement and Attachment A, City shall have the exclusive right to elect which provision shall control. The parties further acknowledge and agree that in the event of any inconsistency between the Request, including attachments thereto, and Vendor's responses, including any attachments thereto, contained in Attachment A, City shall have the exclusive right to elect which provision shall control.

2. DEFINITIONS: As used in this Solicitation/Contract, the following terms shall have the meanings attributed to them below. Additional definitions may be found in the specifications included with this Solicitation/Contract.

2.1. "City" means the City of Charleston, WV, that is identified on the first page of the Solicitation seeking to procure goods or services under this Contract.

2.2. "Bid" or "Proposal" means the vendor's submitted response to this solicitation.

2.3. "Contract" means the binding agreement that is entered into between the City and the Vendor to provide the goods or services requested in the Solicitation.

2.4. "Solicitation" means the official notice of an opportunity to supply the City with goods or services that is published by the City.



Solicitation: 2026-27 ADA Ramp Installation Project (E6 05/26-163)

2.5. “Vendor” or “Vendors” means any entity submitting a bid in response to the Solicitation, the entity that has been selected as the lowest responsible bidder, or the entity that has been awarded the Contract, as context requires.

3. CONTRACT TERM; RENEWAL; EXTENSION: The term of this Contract shall be determined in accordance with the category that has been identified as applicable to this Contract below:

Term Contract Initial Contract Term: The Initial Contract Term will be for a period of _____. Renewal Term: This Contract may be renewed upon the mutual written consent of the City and the Vendor. All requests for renewal must be submitted in writing thirty (30) days prior to the expiration date of the initial contract term or an appropriate renewal term. A Contract renewal shall be in accordance with the terms and conditions of the original contract. Unless otherwise specified below, renewal of this Contract is limited to _____ successive one (1) year periods. Automatic renewal of this Contract is prohibited. This Contract becomes effective on the effective start date listed on the Notice to Proceed.

Fixed Period Contract: This Contract becomes effective upon Vendor’s receipt of the notice to proceed and must be completed within _____ days or by/on the date listed in Section _____ of the Solicitation.

Fixed Period Contract with Renewals: This Contract becomes effective upon Vendor’s receipt of the notice to proceed and part of the Contract more fully described in the attached specifications must be completed within _____ days or by/on the date listed in Section _____ of the Solicitation. Upon completion of the work covered by the preceding sentence, the vendor agrees that:

the contract will continue for _____ years;

the contract may be renewed for _____ successive _____ year periods or shorter periods, provided that they do not exceed the total number of months contained in all available renewals. Automatic renewal of this Contract is prohibited. Renewals must be approved by the Vendor and City.

One-Time Purchase: The term of this Contract shall run from the issuance of the Award Document until all of the goods contracted for have been delivered, but in no event will this Contract extend for more than one fiscal year.



Solicitation: 2026-27 ADA Ramp Installation Project (E6 05/26-163)

Construction/Project: This Contract becomes effective on the effective start date listed on the Notice to Proceed and must be completed within 9 (nine) months of award.

Other: _____ . effective for one year from the date the delivery order is issued. No delivery order may be extended beyond one year after this Contract has expired. This Contract becomes effective on the effective start date listed on the Notice to Proceed.

4. PROCUREMENT OF AGREEMENT: Vendor represents and warrants that no person or selling agency has been employed or retained to solicit or secure this Agreement upon an agreement or understanding for a commission, percentage, brokerage fee, contingent fee, or any other compensation.

Vendor represents and warrants that it is authorized to do business in the State of West Virginia and may lawfully perform the Services and provide the Materials required by this Agreement without violating any Federal, State, or local law or regulation.

The Vendor represents and warrants that the execution, delivery and performance hereof including the performance of the Services and the sale of the Materials have been authorized and approved by all necessary action on its behalf, constitutes its valid and binding obligation and that the same shall not violate any law or agreement binding on or applicable to Vendor.

5. FAIR PRACTICES: Vendor, and each person signing on behalf of Vendor, represents, warrants, and certifies, under penalty of perjury, that to the best of their knowledge and belief:

The prices in Attachment A have been arrived at independently without collusion, consultation, communication, or agreement, for the purpose of restricting competition, as to any matter relating to such price with any other bidder or with any competitor.

Unless otherwise required by law, the prices stated in this Agreement and Attachment A have not been knowingly disclosed by Vendor prior to the proposal opening, directly or indirectly, to any other bidder or to any competitor.

No attempt has been made or will be made by Vendor to induce any other person, partnership, or corporation to submit or not to submit a proposal for the purpose of restricting competition.



Solicitation: 2026-27 ADA Ramp Installation Project (E6 05/26-163)

6. AUTHORITY TO PROCEED: Vendor is authorized to begin performance of this contract upon the date of the Notice to Proceed signed by the City Manager or their designee.

7. QUANTITIES: The quantities required under this Contract shall be determined in accordance with the category that has been identified as applicable to this Contract below.

Open End Contract: Quantities listed in this Solicitation/Award Document are approximations only, based on estimates supplied by the City. It is understood and agreed that the Contract shall cover the quantities actually ordered for delivery during the term of the Contract, whether more or less than the quantities shown.

Service: The scope of the service to be provided will be more clearly defined in the specifications included herewith.

Combined Service and Goods: The scope of the service and deliverable goods to be provided will be more clearly defined in the specifications included herewith.

One-Time Purchase: This Contract is for the purchase of a set quantity of goods that are identified in the specifications included herewith. Once those items have been delivered, no additional goods may be procured under this Contract without an appropriate change order approved by the Vendor and City.

Construction: This Contract is for construction activity more fully defined in the specifications.

8. EMERGENCY PURCHASES: The City may authorize a purchase of goods or services in the open market that Vendor would otherwise provide under this Contract if those goods or services are for immediate or expedited delivery in an emergency. Emergencies shall include, but are not limited to, delays in transportation or an unanticipated increase in the volume of work. An emergency purchase in the open market, approved by the City shall not constitute a breach of this Contract and shall not entitle the Vendor to any form of compensation or damages. This provision does not excuse the City from fulfilling its obligations under a One-Time Purchase contract.

9. REQUIRED DOCUMENTS: In addition to any requirements under the Section of the General Terms and Conditions entitled Licensing, the apparent successful Vendor shall furnish proof of the following licenses, certifications, and/or permits upon request and in a form acceptable to the City. The request may be prior to or after contract award at the City's sole discretion. All of the items checked in this section must be provided to the City by the Vendor as specified:



Solicitation: 2026-27 ADA Ramp Installation Project (E6 05/26-163)

LICENSE(S) : WV Contractor's License

CERTIFICATION(S)

PERMIT(S)

The apparent successful Vendor shall also furnish proof of any additional licenses or certifications contained in the specifications, regardless of whether or not that requirement is listed above.

10. INSURANCE: The apparent successful Vendor shall furnish proof of the insurance identified by a checkmark below prior to Contract award and shall name the City as an additional insured for purposes of this Agreement and the indemnity provisions herein. Vendor shall be responsible for the payment of all deductibles. All policies shall provide primary coverage, shall reflect that the Vendor is responsible for any and all deductibles, and shall otherwise be in such form and with such endorsements and riders as the City shall specify. Insurance coverage required herein shall be furnished by a company approved by the insurance commission of the State of West Virginia. In the event that Vendor's insurer denies coverage or terminates Vendor's insurance coverage, the City may, at its option, terminate this Agreement immediately. The insurance coverages identified below must be maintained throughout the life of this contract. Thirty (30) days prior to the expiration of the insurance policies, Vendor shall provide the City with proof that the insurance mandated herein has been continued. Vendor must also provide the City with immediate notice of any changes in its insurance policies, including but not limited to, policy cancellation, policy reduction, or change in insurers. The apparent successful Vendor shall also furnish proof of any additional insurance requirements contained in the specifications prior to Contract award, regardless of whether that insurance requirement is listed in this section. Vendor must maintain:

Commercial General Liability Insurance in at least an amount of: \$1,000,000.00 per occurrence.

Automobile Liability Insurance in at least an amount of: \$1,000,000.00 per occurrence.



Solicitation: 2026-27 ADA Ramp Installation Project (E6 05/26-163)

Professional/Malpractice/Errors and Omission Insurance in at least an amount of: _____ per occurrence.

Commercial Crime and Third-Party Fidelity Insurance in an amount of: _____ per occurrence.

Cyber Liability Insurance in an amount of: _____ per occurrence.

Builders Risk Insurance in an amount equal to 100% of the amount of the Contract.

Pollution Insurance in an amount of: _____ per occurrence.

Aircraft Liability in an amount of: _____ per occurrence.

11. WORKERS' COMPENSATION INSURANCE: Vendor shall comply with laws relating to workers' compensation, shall maintain workers' compensation insurance when required, and shall furnish proof of workers' compensation insurance upon request.

12. LIQUIDATED DAMAGES: This clause shall in no way be considered exclusive and shall not limit the City's right to pursue any other available remedy. Vendor shall pay liquidated damages in the amount specified below or as described in the specifications:

_____ for _____.

Liquidated Damages Contained in the Specifications.

Liquidated Damages Are Not Included in this Contract.

13. ACCEPTANCE: Vendor's signature on its bid, or on the certification and signature page, constitutes an offer to the City that cannot be unilaterally withdrawn, signifies that the product or service proposed by vendor meets the mandatory requirements contained in the Solicitation for that product or service, unless otherwise indicated, and signifies acceptance of the terms and conditions contained in the Solicitation unless otherwise indicated.

14. PRICING: The pricing set forth herein is firm for the life of the Contract, unless specified elsewhere within this Solicitation/Contract by the City. A Vendor's inclusion of price adjustment provisions in its bid, without an express authorization from the City in the Solicitation to do so, may result in bid disqualification. Notwithstanding the foregoing, Vendor must extend any publicly advertised sale price to the City and invoice at the lower of the contract price or the publicly advertised sale price.



Solicitation: 2026-27 ADA Ramp Installation Project (E6 05/26-163)

15. PAYMENT IN ARREARS: Payments for goods/services will be made in arrears only upon receipt of a proper invoice, detailing the goods/services provided or receipt of the goods/services, whichever is later. Notwithstanding the foregoing, payments for software licenses, subscriptions, or maintenance may be paid monthly or annually in advance.

Requests for payment for Materials provided and Services performed in any month shall be prepared and submitted monthly by Vendor in the form of a proper detailed invoice. The City will pay proper requests for payments within thirty (30) days following City's receipt of a proper request for payment. For contracts involving construction services or architecture and engineering services, the City may withhold ten percent (10%) of each interim payment. Vendor shall provide a certified payroll with each invoice submitted. **Invoices shall be mailed to: City Manager, City of Charleston, P.O. Box 2749, Charleston, WV 25330, or hand delivered to City Manager, 501 Virginia Street East, Charleston, WV.**

City may reject any Services or Materials that do not conform to this Agreement, provided that approval shall not be unreasonably withheld. No payment shall be made until said services are performed to the satisfaction of the City. Vendor shall immediately correct such non-conforming Services or Materials without additional cost to City.

City agrees to pay Vendor the retainage amount accrued and the remaining Total Contract Amount within thirty (30) working days of completion of all the following:

1. Inspection of the Materials and Services by City;
2. Acceptance of the Materials by City;
3. Timely completion of the Services to the satisfaction of City; and
4. Receipt by City of a proper invoice from Vendor.

16. TAXES: The Vendor shall pay and be solely responsible for any applicable sales, use, personal property, or any other taxes directly or indirectly arising out of this Contract and the transactions contemplated thereby, including but not limited to municipal Business and Occupation Taxes. The City is exempt from federal and state taxes and will not pay or reimburse such taxes.

17. ADDITIONAL FEES, INTEREST: Vendor is not permitted to charge additional fees or assess additional charges that were not either expressly provided for in the solicitation published by the City, included in the Contract, or included in the unit price or lump sum bid amount that Vendor is required by the solicitation to provide. Including such fees or charges as notes to the solicitation may result in rejection of Vendor's bid. Requesting such fees or



Solicitation: 2026-27 ADA Ramp Installation Project (E6 05/26-163)

charges be paid after the contract has been awarded may result in cancellation of the contract.

18. CANCELLATION: City shall have the right to terminate this Agreement, in whole or in part, in accordance with the following, or for reasons set forth elsewhere in this Agreement:

- A. Upon the default by Vendor under any covenant or other term or condition of this Agreement or Attachment A, or if any warranty or representation made by Vendor is untrue in any material respect; or
- B. Upon Vendor's becoming insolvent or upon commencement under the Bankruptcy Act of any similar proceeding either voluntarily or involuntarily; or
- C. If funds are not appropriated by City for the purposes of this Agreement. In the event of City's termination pursuant to this section of the Agreement, City agrees to compensate Vendor for all Services and Materials for which funds were appropriated, and which were satisfactorily performed through the date of termination; or
- D. Upon failure by Vendor to perform the Services with sufficient and qualified employees, sufficient and suitable equipment, or with sufficient and suitable Materials to assure the prompt and satisfactory completion of the work; or
- E. If Vendor performs the Services unsuitably or neglects or refuses to remove and replace non-conforming Materials or to correct non-conforming Services to the satisfaction of the City; or
- F. If Vendor fails to maintain General Liability insurance as required herein, with the City and its agents as additional insureds, with limits of at least \$1 million; or
- G. For any other lawful reason, provided that the City provides thirty (30) days' written notice to the Vendor.

Upon such termination resulting from the default of Vendor, City may, in addition to its other rights and remedies hereunder, institute a civil action for damages or specific performance and exercise such other rights and remedies as it may have under applicable law.



Solicitation: 2026-27 ADA Ramp Installation Project (E6 05/26-163)

In the event of termination, all finished or unfinished documents, data, studies, surveys, drawings, maps, models, photographs, and reports prepared by Vendor pursuant to this Agreement shall, at the option of the City, become property of the City.

19. TIME: Time is of the essence regarding all matters of time and performance in this Contract. Vendor shall complete the Services to City's satisfaction:

On or before Within 9 months of Notice to Proceed

Within a reasonable time of receiving the notice to proceed

unless the term herein shall be extended by the mutual written agreement of the Parties hereto. If Vendor fails to perform its obligation to provide the Materials and complete the Services by such date, or otherwise breaches the terms of this Agreement or Attachment A, City may, but without any obligation to do so, terminate this Agreement immediately, call Vendor's bonds, engage another vendor or vendors to provide the Materials and/or complete the Services as City may determine, and seek monetary damages from Vendor in addition to other remedies available under this Agreement, Attachment A, or applicable law. Vendor shall not be responsible for: (1) delays occasioned by circumstances beyond the control of Vendor, including property access, labor strikes, lockouts and unavoidable casualties or causes; or (2) changes ordered by City, unless the changes were necessary to correct defects or non-compliance of the Services or the Materials.

20. COMPLIANCE WITH LAWS: Vendor shall comply with all applicable federal, state, and local laws, regulations, and ordinances. By submitting a bid, Vendor acknowledges that it has reviewed, understands, and will comply with all applicable laws, regulations, and ordinances. If Vendor fails to comply with the aforementioned laws and/or requirements, the City may, at its discretion, take appropriate action, including, but not limited to, calling Vendor's bonds and/or terminating this Agreement immediately.

20.1. SUBCONTRACTOR COMPLIANCE: Vendor shall notify all subcontractors providing commodities or services related to this Contract that, as subcontractors, they too are required to comply with all applicable laws, regulations, and ordinances. Notification under this provision must occur prior to the performance of any work under the contract by the subcontractor.



Solicitation: 2026-27 ADA Ramp Installation Project (E6 05/26-163)

21. PROHIBITED ACTIVITY: During the performance of this Agreement, Vendor or personnel employed hereunder shall not use their position as a Contractor for the City of Charleston to directly promote political activities, inherently religious activities, lobbying, political patronage, or nepotism activities.

22. DILIGENT REVIEW BY VENDOR AND ABILITY TO PERFORM THE SERVICES: Vendor agrees and acknowledges that:

- A. Vendor has examined and carefully studied this Agreement, Attachment A hereto, and other related data identified in the request for bids and the plans, specifications, and other specified provisions thereto;
- B. Vendor has visited the site of the project, has become familiar with it, and is satisfied as to the general, local, and site conditions that may affect cost, progress, provision of the Materials, and performance of the Services;
- C. Vendor has obtained and carefully studied (or assumes responsibility for doing so) all additional or supplementary examinations, investigations, explorations, tests, studies, and data concerning conditions (surface, subsurface, and underground facilities) at or contiguous to the site of the project which may affect cost, progress, provision of the Materials or performance of the Services or which relate to any aspect of the means, methods, techniques, sequences, and procedures of construction expressly required by this Agreement, Attachment A, and all safety precautions and programs incident thereto;
- D. Vendor does not consider that any further examinations, investigations, explorations, tests, studies, or data are necessary for the provision of the Materials or performance of the Services at the Total Contracted Price stated herein.
- E. Vendor has given the City Manager and/or the design engineer written notice of all conflicts, errors, ambiguities, or discrepancies that Vendor has discovered in this Agreement and Attachment A hereto, and the written resolution thereof by the City Manager and/or design engineer is acceptable to Vendor; and



Solicitation: 2026-27 ADA Ramp Installation Project (E6 05/26-163)

- F. This Agreement and Attachment A hereto are generally sufficient to indicate and convey understanding of all terms and conditions for provision of the Materials and performance of the Services to the satisfaction of the City.

23. TRAFFIC CONTROL: Vendor shall always conduct work in such a manner and in such sequence as will assure the least interference with traffic. During the performance of the Services, Vendor shall be solely responsible for putting in place adequate safety measures and warnings for both pedestrians and vehicular traffic, including, but not limited to, barricades, flashing lights, flaggers, and all other measures required by law or necessary under the circumstances. Vendor should anticipate pedestrian traffic and shall provide adequate measures to protect the work and the public.

24. RESPONSIBILITY OF AVOIDING STRUCTURES: Vendor shall assume full responsibility for the protection of all property owned by City or by any third party in the vicinity of the project. Vendor shall notify the City Manager if Vendor's work encroaches on structures or property owned by a third party in the area of the project. Vendor shall replace or repair at Vendor's expense any and all property of any kind damaged as a result of Vendor's work at no additional cost to the City.

25. ACCESS: City agrees to take all actions necessary to allow Vendor and its subcontractor(s) authority to enter the property upon which Vendor's Services are to be performed. Vendor shall take all reasonable precautions to minimize any damage to the property covered by the Agreement and to any adjoining property. Any cost of correction, repair, or replacement to such property, or adjoining properties, shall be borne by Vendor.

26. CLEAN UP: Vendor shall pick up all debris and materials resulting from its work and remove it from the job site. Vendor shall dispose of all debris resulting from its work at its own expense and in conformity with applicable Federal, State, and local health and sanitary codes and laws. Vendor shall be responsible for complete and lawful removal of any and all hazardous material/debris resulting from Vendor's work activities from the job site. The final clean up shall be reviewed and approved by the City Engineer prior to final payment.

27. DISPUTE RESOLUTION, JURISDICTION AND VENUE: Any references to arbitration contained in the Agreement are hereby deleted, as is any requirement to waive a jury trial. If any breach, default, or other dispute arises out of this Agreement, the Parties agree that they will exercise good faith and commercially reasonable efforts to resolve said breach, default, or other dispute through negotiation and/or mediation. If the parties cannot resolve the matter without litigation, the Parties acknowledge and agree that either the Circuit Court of



Solicitation: 2026-27 ADA Ramp Installation Project (E6 05/26-163)

Kanawha County, West Virginia, or the Federal District Court for the Southern District of West Virginia shall have exclusive jurisdiction to resolve the breach, default, or other dispute giving rise to the litigation. Any language requiring or permitting disputes under the Agreement to be resolved in any other court is deleted. Vendor acknowledges and agrees that resolution agreements reached through consultation and negotiation, or any other form of dispute resolution, may be subject to approval by City's governing body during a public meeting.

28. MODIFICATIONS: This writing is the parties' final expression of intent. Notwithstanding anything contained in this Contract to the contrary no modification of this Contract shall be binding without mutual written consent of the City and the Vendor and, for any modification to be enforced against City, shall reference the Section of this Agreement to be modified and specifically identify the term, condition, or obligation to be modified. Any change to existing contracts that adds work or changes contract cost, and was not included in the original contract, must be approved by the City.

29. WAIVER: The failure of either party to insist upon a strict performance of any of the terms or provision of this Contract, or to exercise any option, right, or remedy herein contained, shall not be construed as a waiver or a relinquishment for the future of such term, provision, option, right, or remedy, but the same shall continue in full force and effect. Any waiver must be expressly stated in writing and signed by the waiving party.

30. SUBSEQUENT FORMS: The terms and conditions contained in this Contract shall supersede any and all subsequent terms and conditions which may appear on any form documents submitted by Vendor to the City, such as price lists, order forms, invoices, sales agreements, or maintenance agreements, and includes internet websites or other electronic documents. Acceptance or use of Vendor's forms does not constitute acceptance of the terms and conditions contained thereon.

31. ASSIGNMENT: Neither this Contract nor any monies due, or to become due hereunder, may be assigned by the Vendor without the express written consent of the City.

32. WARRANTY: The Vendor expressly warrants that the goods and/or services covered by this Contract will: (a) conform to the specifications, drawings, samples, or other description furnished or specified by the Agency; (b) be merchantable and fit for the purpose intended; and (c) be free from defect in material and workmanship.

33. CITY EMPLOYEES: City employees are not permitted to utilize this Contract for personal use, and the Vendor is prohibited from permitting or facilitating the same.



Solicitation: 2026-27 ADA Ramp Installation Project (E6 05/26-163)

34. PRIVACY, SECURITY, AND CONFIDENTIALITY: The Vendor agrees that it will not disclose to anyone, directly or indirectly, any such personally identifiable information or other confidential information gained from the City, unless the individual who is the subject of the information consents to the disclosure in writing or the disclosure is made pursuant to the City's policies, procedures, and rules.

35. YOUR SUBMISSION IS A PUBLIC DOCUMENT: Vendor's entire response to the Solicitation and the resulting Contract are public documents. As public documents, they will be disclosed to the public following the bid/proposal opening or award of the contract, as required by the Freedom of Information Act West Virginia Code §§ 29B-1-1 et seq. DO NOT SUBMIT MATERIAL YOU CONSIDER TO BE CONFIDENTIAL, A TRADE SECRET, OR OTHERWISE NOT SUBJECT TO PUBLIC DISCLOSURE. Submission of any bid, proposal, or other document to the City constitutes your explicit consent to the subsequent public disclosure of the bid, proposal, or document. The City will disclose any document labeled "confidential," "proprietary," "trade secret," "private," or labeled with any other claim against public disclosure of the documents, to include any "trade secrets" as defined by West Virginia Code § 47-22-1 et seq. All submissions are subject to public disclosure without notice.

36. LICENSING: In accordance with West Virginia Code of State Rules § 148-1-6.1.e, Vendor must be licensed and in good standing in accordance with any and all state and local laws and requirements by any state or local agency of West Virginia, including, but not limited to, the West Virginia Secretary of State's Office, the West Virginia State Tax Division, West Virginia Offices of the Insurance Commissioner, or any other state agency or political subdivision. Obligations related to political subdivisions may include, but are not limited to, business licensing, business and occupation taxes, inspection compliance, permitting, etc. Upon request, the Vendor must provide all necessary releases to obtain information to enable the City to verify that the Vendor is licensed and in good standing with the above entities.

36.1 SUBCONTRACTOR COMPLIANCE: Vendor shall notify all subcontractors providing commodities or services related to this Contract that, as subcontractors, they too are required to be licensed, in good standing, and up to date on all state and local obligations as described in this section. Obligations related to political subdivisions may include, but are not limited to, business licensing, business and occupation taxes, inspection compliance, permitting, etc. Notification under this provision must occur prior to the performance of any work under the contract by the subcontractor.



Solicitation: 2026-27 ADA Ramp Installation Project (E6 05/26-163)

37. ANTITRUST: In submitting a bid to, signing a contract with, or accepting an Award Document from the City, the Vendor agrees to convey, sell, assign, or transfer to the City all rights, title, and interest in and to all causes of action it may now or hereafter acquire under the antitrust laws of the United States and the State of West Virginia for price fixing and/or unreasonable restraints of trade relating to the particular commodities or services purchased or acquired by the City. Such assignment shall be made and become effective at the time the City tenders the initial payment to Vendor.

38. VENDOR NON-CONFLICT: Vendor represents and warrants that neither it nor any of its directors, officers, members, partners or employees, has any interest nor shall they acquire any interest, directly or indirectly, which would or may conflict or compromise in any manner or degree with the performance of the Services or the provision of Materials as herein provided. Any such interests shall be promptly presented in detail to the City.

39. VENDOR RELATIONSHIP: The relationship of the Vendor to the City shall be that of an independent contractor, and no principal-agent relationship or employer-employee relationship is contemplated or created by this Contract. The Vendor, as an independent contractor, is solely liable for the acts and omissions of its employees and agents. Vendor shall be responsible for selecting, supervising, and compensating any and all individuals employed pursuant to the terms of this Solicitation and resulting contract. Neither the Vendor nor any employees or subcontractors of the Vendor shall be deemed to be employees of the City for any purpose whatsoever. Vendor shall be exclusively responsible for payment of employees and contractors for all wages and salaries, taxes, withholding payments, penalties, fees, fringe benefits, professional liability insurance premiums, contributions to insurance and pension, or other deferred compensation plans, including but not limited to, Workers' Compensation and Social Security obligations, licensing fees, etc. and the filing of all necessary documents, forms, and returns pertinent to all of the foregoing. Vendor shall hold harmless the City and shall provide the City with a defense against any and all claims, including, but not limited to, the foregoing payments, withholdings, contributions, taxes, Social Security taxes, and employer income tax returns.

40. INDEMNIFICATION: In addition to, and not in lieu of the indemnity provisions set forth in this Section, Vendor agrees that it shall indemnify, defend and hold harmless City, its officers, employees and agents (hereinafter collectively, "City" for purposes of the indemnity, defense, hold harmless and insurance obligations contained in this Agreement) from and against any and all claims, demands, obligations, causes of action, lawsuits, fines, costs, judgments and damages of any character whatsoever, and all expenses associated therewith (including, but not limited to, reasonable attorney's fees and costs), arising from



Solicitation: 2026-27 ADA Ramp Installation Project (E6 05/26-163)

or related in any way to: (i) the operations of Vendor, its officers, agents, employees, subcontractors and its related or affiliated companies (hereinafter collectively, "Vendor" for purposes of the indemnity, defense and hold harmless obligations contained in this Agreement); (ii) Vendor's provision of the Services or Materials; (iii) any act or omission, negligence or misconduct of Vendor; (iv) a breach of this Agreement; (v) failure of Vendor to complete any required work as specified in the Agreement; or (vi) failure of Vendor to perform any obligation contained in the Agreement or otherwise agreed to by Vendor, whether written or oral. Vendor specifically acknowledges that the indemnification, defense, and hold harmless obligations imposed by this Agreement require Vendor to indemnify and defend City regardless of whether or not any claimant or litigant also alleges that City was negligent. Further, Vendor agrees that its duty to defend and indemnify City does not require a judicial determination of the Vendor's negligence as a precondition of the duty to indemnify and defend City.

In addition to, and not in lieu of the indemnity provisions set forth in this Section, Vendor shall be solely responsible for all physical injuries or death to its officers, agents, employees and subcontractors and, consistent with the obligations imposed by this Agreement, shall indemnify, defend and hold harmless City for such injury or death. Vendor shall be solely responsible for the safety and protection of all of its employees, whether due to the acts and omissions, negligence, fault, or default of Vendor or not. Vendor hereby agrees to purchase and carry workers' compensation insurance for all of its employees and to ensure that all of its subcontractors purchase and carry workers' compensation insurance for all of their employees.

In addition to, and not in lieu of the indemnity provisions set forth in this Section, Vendor shall be solely responsible for any and all damage to any property of the City or of any third-party related in any way to Vendor's operations, provision of the Services or Materials, or any act or omission, negligence or misconduct of Vendor. Consistent with the obligations imposed by this Agreement, Vendor shall indemnify, defend and hold harmless City for any and all such damage, and, in the event of damage to any property of City, shall promptly reimburse City for all costs and expenses of any character upon Vendor's receipt of a demand for reimbursement by City.

The indemnity provided for in the Section herein shall be deemed in addition to and in no way a limitation upon the right of common law indemnification of City, its officers, employees, and agents from Vendor.



Solicitation: 2026-27 ADA Ramp Installation Project (E6 05/26-163)

41. NO DEBT CERTIFICATION: The City is prohibited from awarding a contract to any bidder that owes a debt to the City. By submitting a bid, or entering into a contract with the City, Vendor is affirming that (1) for construction contracts, the Vendor is not in default on any monetary obligation owed to the City (2) for all other contracts, neither the Vendor nor any related party owe a debt as defined above, and neither the Vendor nor any related party are in employer default as defined in the statute cited above unless the debt or employer default is permitted under the statute.

42. REPORTS: Vendor shall provide the City with the following reports identified by a checked box below:

Such reports as the City may request.

Quarterly reports detailing the total quantity of purchases in units and dollars, along with a listing of purchases by agency.

43. BOOKS, RECORDS, AND AUDIT BY CITY: All vouchers or invoices presented for payment to be made hereunder, and the books, records, and accounts upon which said vouchers or invoices are based, are subject to audit by appropriate City officials. Vendor agrees to maintain and retain separate and accurate books, records, documents, and other evidence and accounting procedures and practices that sufficiently and properly reflect all direct and indirect costs of any nature expended in the performance of this Agreement.

Vendor agrees to retain all books, records, and other documents relevant to this Agreement for ten years after the final payment or termination of this Agreement, whichever is later. City, State, and Federal auditors, and any other persons duly authorized by the City, shall have full access to and the right to examine any of said materials during said period.

Vendor shall submit any and all documentation and justification in support of expenditures or fees under this Agreement as may be required by City.

Vendor shall not be entitled to final payment under the Agreement until all requirements of this Agreement and Attachment A have been satisfactorily met.

44. VENDOR'S REPRESENTATION, WARRANTIES, AND GUARANTEE; PROHIBITION AGAINST USED OR REFURBISHED: Unless otherwise agreed to in writing by City or expressly permitted by City in Attachment A, Vendor hereby represents, warrants and agrees that the Materials used in connection with the Agreement are new, in good and marketable condition, have never been used, are sufficient for their intended purposes, are in



Solicitation: 2026-27 ADA Ramp Installation Project (E6 05/26-163)

compliance with the specifications in Attachment A, and that Vendor owns them and has the right to sell and convey them to City free of liens and encumbrances. Vendor hereby assigns to City all rights to any and all warranties and/or guarantees, whether express or implied, made to Vendor by the manufacturers or distributors of the Materials or any part thereof. Vendor agrees to assist the City in enforcing any and all warranties and/or guarantees related to the Materials.

Vendor further warrants that, if any of its completed Services fail to conform to this Agreement or Attachment A, Vendor shall, at its own expense, and provided Vendor is notified of such defect or non-conformity within one year of the completion of the Services, either perform corrective services at no cost to City as may be required to correct such defect or non-conformity or refund to City the amount paid to Vendor for Services that are defective or non-conforming.

45. PROTECTION OF WORK AND MATERIALS; SUSPENSION OF WORK: Vendor shall at all times be solely responsible for the protection of all work and Materials against damage or injury. In the event of temporary suspension of work for any reason, including, but not limited to, inclement weather, Vendor shall immediately take all action(s) necessary to ensure the protection of all work and Materials against damage or injury.

City may suspend work if the City Manager or his designee determines that suspension is in the City's best interest and/or the City elects to terminate this Agreement for any of the provisions contained in this Agreement. The City Manager and/or the designee will deliver to Vendor a Notice of Suspension specifying the extent and duration of the suspension and the effective date thereof. Upon receipt of such Notice of Suspension, Vendor shall immediately proceed to stop work, as specified in the notice, place no further subcontracts or orders for materials (except as necessary to complete any work that is not subject to suspension), and take all action(s) necessary, including any action(s) that the City Manager may direct, for the protection and preservation of the Materials and any property related to this Agreement.

If, in the opinion of the City Manager, any work or Materials have been damaged or injured by reason of failure on the part of the Vendor or his subcontractors to protect their work or Materials, such Materials shall be removed and replaced at the expense of the Vendor.

46. GOVERNING LAW: The Agreement shall be deemed to be executed in the City of Charleston, State of West Virginia, regardless of the domicile of Vendor, and shall be governed by the laws of the City of Charleston and State of West Virginia. This provision replaces any references to any other State's governing law.



Solicitation: 2026-27 ADA Ramp Installation Project (E6 05/26-163)

The parties agree that any and all claims asserted by or against City arising under this Agreement, or related thereto, shall be heard and determined either in the United States District Court for the Southern District of West Virginia or in the Circuit Court of Kanawha County, West Virginia.

47. CONDITIONS PRECEDENT: This Agreement shall neither be binding on City nor effective until the execution of this Agreement by the City Manager or their authorized representative. The requirements of this section of this Agreement shall be in addition to, and not in lieu of, any approval or authorization otherwise required for this Agreement to be effective and for the expenditure of City funds.

48. GENERAL RELEASE; WAIVER OF MECHANIC'S LIENS: The acceptance by the Vendor and its assignees of the final payment under this Agreement, whether by check, voucher, judgment of any court of competent jurisdiction or any other administrative means, shall constitute and operate as a general release to City from any and all claims of and liability to Vendor arising out of the performance of this Agreement. Vendor waives its right to file a mechanic's or other lien in connection with the provision of the Services or Materials.

49. NO CLAIM AGAINST OFFICER, AGENT, OR EMPLOYEES: No claim whatsoever shall be made by Vendor against any officer, employee, or agent of City for, or on account of, anything done or omitted in connection with this Contract.

50. NOTICE BETWEEN VENDOR AND CITY: Vendor and City hereby designate the business mailing addresses set forth in this Agreement as the places where all notice, directions, or communications from one such party to the other party shall be delivered, or to which they shall be mailed. Such address may be changed at any time by either party by written notice to the other party in the manner prescribed herein.

Vendor shall identify and provide a superintendent, foreman, or supervisor who shall have the authority to act for Vendor for the purposes of this Agreement.

51. FORCE MAJEURE: In the event of any condition or event, not existing as of the date of execution of the Agreement, not reasonably foreseeable as of such date, and not reasonably within the control of the parties which prevents in whole or in material part the performance of either party of its obligations hereunder, the obligations of each party to perform under the Agreement shall be suspended until the cause no longer prevents or makes impracticable either party's performance at which time all obligations shall resume. Either party shall have the right to terminate this Agreement upon written notice to the other should the condition or event continue for a period of two (2) days or more. Force Majeure events or conditions



Solicitation: 2026-27 ADA Ramp Installation Project (E6 05/26-163)

shall include, but not be limited to, riots, war, governmental action, strikes or lockouts (other than the parties), epidemics, floods, earthquakes, and explosions.

52. ENTIRE AGREEMENT: This Agreement, including Attachment A and all other exhibits attached hereto, and documents incorporated herein by reference, constitutes the entire Agreement between City and Vendor and supersedes all prior or contemporaneous communications, whether electronic, oral, or written, between City and Vendor.

53. HEADINGS: The section headings and subheadings contained in this Agreement are included for convenience only and shall not limit or otherwise affect the terms of this Agreement.

54. SEVERABILITY: If any provision of this Agreement is held invalid, the remainder of the Agreement shall not be affected thereby, and all other parts of this Agreement shall nevertheless be in full force or effect.

55. SURVIVAL: The insurance and indemnity obligations contained in this Agreement herein shall remain in full force and effect and shall survive the completion or earlier termination of this Agreement.



Solicitation: 2026-27 ADA Ramp Installation Project (E6 05/26-163)

ADDITIONAL TERMS AND CONDITIONS (Construction Contracts Only)

1. CONTRACTOR'S LICENSE: As of June 15, 2021, West Virginia Code § 21-11-2 and § 30-42-2 require that all persons desiring to perform contracting work in this state be licensed. The West Virginia Contractors Licensing Board is empowered to issue the contractor's license. Applications for a contractor's license may be made by contacting the West Virginia Contractor Licensing Board. The apparent successful Vendor must furnish a copy of its contractor's license prior to the issuance of a contract award document.

2. BONDS: The following bonds must be submitted:

BID BOND: Pursuant to the requirements contained in W. Va. Code § 5-22-1(c), All Vendors submitting a bid on a construction project shall furnish a valid bid bond in the amount of five percent (5%) of the total amount of the bid protecting the State of West Virginia. **THE BID BOND MUST BE SUBMITTED WITH THE BID OR VENDOR'S BID WILL BE DISQUALIFIED.**

PERFORMANCE BOND: The apparent successful Vendor shall provide a performance bond in the amount of 100% of the contract. The performance bond must be received by the City prior to Contract award.

LABOR/MATERIAL PAYMENT BOND: The apparent successful Vendor shall provide a labor/material payment bond in the amount of 100% of the Contract value. The labor/material payment bond must be delivered to the City prior to Contract award.

MAINTENANCE BOND: The apparent successful Vendor shall provide a two (2) year maintenance bond covering the roofing system if the work impacts an existing roof. The amount of the bond must be equal to the price associated with the percentage of the project impacting the roof. The maintenance bond must be issued and delivered to the City prior to Contract award.

At a minimum, all construction projects require a bid bond, performance bond, and labor/material payment bond. Failure on the part of the City to checkmark the required bonds above does not relieve the Vendor from the legal requirement of providing these bonds. In lieu of the Bid Bond, the Vendor may provide certified checks or cashier's checks. Any certified check or cashier's check in lieu of the bid bond must be of the same amount required of the Bid Bond and delivered with the bid.



Solicitation: 2026-27 ADA Ramp Installation Project (E6 05/26-163)

3. DRUG-FREE WORKPLACE AFFIDAVIT: W. Va. Code § 21-1D-5 provides that any solicitation for a public improvement contract requires each Vendor that submits a bid for the work to submit an affidavit that the Vendor has a written plan for a drug-free workplace policy. If the affidavit is not submitted with the bid submission, the City shall promptly request by telephone and electronic mail that the low bidder and second low bidder provide the affidavit within one business day of the request. Failure to submit the affidavit within one business day of receiving the request shall result in disqualification of the bid. To comply with this law, Vendor should complete the enclosed drug-free workplace affidavit and submit the same with its bid. Failure to submit the signed and notarized drugfree workplace affidavit or a similar affidavit that fully complies with the requirements of the applicable code, within one business day of being requested to do so, shall result in disqualification of Vendor's bid. Pursuant to W. Va. Code 21-1D-2(b) and (k), this provision does not apply to public improvement contracts the value of which is \$100,000 or less or temporary or emergency repairs.

3.1. DRUG-FREE WORKPLACE POLICY: Pursuant to W. Va. Code § 21-1D-4, Vendor and its subcontractors must implement and maintain a written drug-free workplace policy that complies with said article. The awarding public authority shall cancel this contract if: (1) Vendor fails to implement and maintain a written drug-free workplace policy described in the preceding paragraph, (2) Vendor fails to provide information regarding implementation of its drug-free workplace policy at the request of the public authority; or (3) Vendor provides to the public authority false information regarding the contractor's drug-free workplace policy. Pursuant to W. Va. Code 21-1D-2(b) and (k), this provision does not apply to public improvement contracts the value of which is \$100,000 or less or temporary or emergency repairs.

4. DRUG FREE WORKPLACE REPORT: Pursuant to W. Va. Code § 21-1D-7b, no less than once per year, or upon completion of the project, every contractor shall provide a certified report to the public authority which let the contract.

4.1. The report shall include:

(1) Information to show that the education and training service to meet the requirements of West Virginia Code § 21-1D-5 was provided

(2) The name of the laboratory certified by the United States Department of Health and Human Services or its successor that performs the drug tests



Solicitation: 2026-27 ADA Ramp Installation Project (E6 05/26-163)

(3) The average number of employees in connection with the construction on the public improvement

(4) Drug test results for the following categories, including the number of positive tests and the number of negative tests

(A) Pre-employment and new hires

(B) Reasonable suspicion

(C) Post-accident

(D) Random

Vendor should utilize the attached Certified Drug Free Workplace Report Coversheet when submitting the report required hereunder. Pursuant to W. Va. Code 21-1D-2(b) and (k), this provision does not apply to public improvement contracts the value of which is \$100,000 or less or temporary or emergency repairs.

5. AIA DOCUMENTS: All construction contracts that will be completed under W. Va. Code § 5-22-1 in conjunction with architectural services procured under W. Va. Code § 5G-1 will be governed by the terms and conditions contained herein, in addition to AIA documents that may be necessary on a case-by-case basis. In any case, the terms and conditions of this document shall prevail over anything contained in the AIA Documents or the Supplementary Conditions.

6. PROHIBITION AGAINST GENERAL CONDITIONS: Notwithstanding anything contained in the AIA Documents or the Supplementary Conditions, the City will not pay for general conditions, winter conditions, or any other condition representing a delay in the contracts. The Vendor is expected to mitigate delay costs to the greatest extent possible, and any costs associated with Delays must be specifically and concretely identified. The City will not consider an average daily rate multiplied by the number of days extended to be an acceptable charge.

7. SUBCONTRACTOR LIST SUBMISSION: In accordance with W. Va. Code § 5-22-1, the apparent low bidder on a contract valued at more than \$250,000.00 for the construction, alteration, decoration, painting, or improvement of a new or existing building or structure shall submit a list of all subcontractors who will perform more than \$25,000.00 of work on the project including labor and materials. (This section does not apply to any other construction projects, such as highway, mine reclamation, water, or sewer projects.) The subcontractor list shall be provided to the City within one business day of the opening of bids



Solicitation: 2026-27 ADA Ramp Installation Project (E6 05/26-163)

for review. If the apparent low bidder fails to submit the subcontractor list, the City shall promptly request by telephone and electronic mail that the low bidder and second low bidder provide the subcontractor list within one business day of the request. Failure to submit the subcontractor list within one business day of receiving the request shall result in disqualification of the bid. If no subcontractors who will perform more than \$25,000.00 of work are to be used to complete the project, the apparent low bidder must make this clear on the subcontractor list, in the bid itself, or in response to the City's request for the subcontractor list.

7.1. Required Information. The subcontractor list must contain the following information:

1. Bidder's name
2. Name of each subcontractor performing more than \$25,000 of work on the project.
3. The license number of each subcontractor, as required by W. Va. Code § 30-42-1 et. seq.
4. If applicable, a notation that no subcontractor will be used to perform more than \$25,000.00 of work. (This item is not required if the vendor makes this clear in the bid itself or in documentation following the request for the subcontractor list.)

7.2. Subcontractor List Submission Form: The subcontractor list may be submitted in any form, as long as the required information noted above is included. If any information is missing from the bidder's subcontractor list submission, it may be obtained from other documents such as bids, emails, letters, etc. that accompany the subcontractor list submission.

7.3. Substitution of Subcontractor: Written approval must be obtained from the City before any subcontractor substitution is permitted.

7.3.1. Substitutions are not permitted unless:

1. The subcontractor listed in the original bid has filed for bankruptcy;
2. The subcontractor in the original bid has been debarred or suspended
3. The contractor certifies in writing that the subcontractor listed in the original bid fails, is unable, or refuses to perform their subcontract.



Solicitation: 2026-27 ADA Ramp Installation Project (E6 05/26-163)

ADDITIONAL TERMS AND CONDITIONS

(Architectural and Engineering Contracts Only)

1. PLAN AND DRAWING DISTRIBUTION: All plans and drawings must be completed and available for distribution at least five business days prior to a scheduled pre-bid meeting for the construction or other work related to the plans and drawings.

2. PROJECT ADDENDA REQUIREMENTS: The Architect/Engineer and/or City shall be required to abide by the following schedule in issuing construction project addenda. The Architect/Engineer shall prepare any addendum materials for which it is responsible, and a list of all vendors that have obtained drawings and specifications for the project. The Architect/Engineer shall then send a copy of the addendum materials and the list of vendors to the City for which the contract is issued to allow the City to make any necessary modifications. The City shall send the addendum to all interested vendors and, if necessary, extend the bid opening date. Any addendum should be received by the City at least fourteen (14) days prior to the bid opening date.

3. PRE-BID MEETING RESPONSIBILITIES: The Architect/Engineer shall be available to attend any pre-bid meeting for the construction or other work resulting from the plans, drawings, or specifications prepared by the Architect/Engineer.

4. AIA DOCUMENTS: All construction contracts that will be completed under W. Va. Code §5-22-1 in conjunction with architectural services procured under W. Va. Code §5G-1 will be governed by the terms and conditions contained herein, in addition to AIA documents that may be necessary on a case-by-case basis. In any case, the terms and conditions of this document shall prevail over anything contained in the AIA Documents or the Supplementary Conditions.

5. GREEN BUILDINGS MINIMUM ENERGY STANDARDS: In accordance with West Virginia Code § 22-29-4, all new building construction projects of public agencies that have not entered the schematic design phase prior to July 1, 2012, or any building construction project receiving state grant funds and appropriations, including public schools, that have not entered the schematic design phase prior to July 1, 2012, shall be designed and constructed complying with the ICC International Energy Conservation Code, adopted by the State Fire Commission, and the ANSI/ASHRAE/IESNA Standard 90.1-2007: Provided, That if any construction project has a commitment of federal funds to pay for a portion of such project, this provision shall only apply to the extent such standards are consistent with the federal standards.



Solicitation: 2026-27 ADA Ramp Installation Project (E6 05/26-163)

Contact and Signature

DESIGNATED CONTACT: Vendor appoints the individual identified in this Section as the Contract Administrator and the initial point of contact for matters relating to this Contract.

(Printed Name and Title) _____

(Address) _____

(Phone Number) _____

(Email address) _____

CERTIFICATION AND SIGNATURE: By signing below, I certify that: I have reviewed this Solicitation/Agreement, including all of these Terms and Conditions as well as Attachment A, in its entirety; that I understand the requirements, terms and conditions, and other information contained herein; that this bid constitutes an offer to the City that cannot be withdrawn; that the product or service proposed meets the mandatory requirements contained in the Solicitation, unless otherwise stated herein; that the Vendor accepts the terms and conditions contained in the Solicitation, unless otherwise stated herein; that I am submitting this bid, offer or proposal for review and consideration; that this bid or offer was made without prior understanding, agreement, or connection with any entity submitting a bid or offer for the same material, supplies, equipment or services; that this bid or offer is in all respects fair and without collusion or fraud; that this Contract is accepted or entered into without any prior understanding, agreement, or connection to any other entity that could be considered a violation of law; that I am authorized by the Vendor to execute and submit this bid, offer, or proposal, or any documents related thereto on Vendor's behalf; that I am authorized to bind the vendor in a contractual relationship; and that to the best of my knowledge, the vendor has properly registered with any entity that may require registration.

VENDOR SIGNATURE

(Company) _____

(Signature) _____

(Printed Name) _____

(Title) _____

(Date) _____

(Phone Number) _____



Solicitation: 2026-27 ADA Ramp Installation Project (E6 05/26-163)

(Email Address) _____

(Mail Address) _____

CITY SIGNATURE

CITY OF CHARLESTON, A WEST VIRGINIA MUNICIPAL CORPORATION

(Signature) _____

(Printed Name) _____

(Title) _____

(Date) _____

(Phone Number) _____

(Email Address) _____

(Mail Address) _____



City of Charleston, WV

Click or tap here to enter text.

INSTRUCTIONS TO VENDORS SUBMITTING BIDS

1. REVIEW DOCUMENTS THOROUGHLY: The attached documents contain a solicitation for bids. Please read these instructions and all documents attached in their entirety. These instructions provide critical information about requirements that if overlooked could lead to disqualification of a Vendor's bid. All bids must be submitted in accordance with the provisions contained in these instructions and the Solicitation. Failure to do so may result in disqualification of Vendor's bid.

2. MANDATORY TERMS: The Solicitation may contain mandatory provisions identified by the use of the words "must," "will," and "shall." Failure to comply with a mandatory term in the Solicitation will result in bid disqualification.

2A. PREBID MEETING: The item identified below shall apply to this Solicitation.

A pre-bid meeting will not be held prior to bid opening

A MANDATORY PRE-BID meeting will be held at the following place and time:

Address:	City Engineering Office
	114 Dickinson Street
	Charleston, WV 25301
Date:	Tuesday, May 19th 2026
Time:	1:00pm

All Vendors submitting a bid must attend the mandatory pre-bid meeting. Failure to attend the mandatory pre-bid meeting shall result in disqualification of the Vendor's bid. No one individual is permitted to represent more than one vendor at the pre-bid meeting. Any individual that does attempt to represent two or more vendors will be required to select one vendor to which the individual's attendance will be attributed. The vendors not selected will be deemed to have not attended the pre-bid meeting unless another individual attended on their behalf. The required attribution of attendance to a single vendor should be addressed during the pre-bid but may occur at any time deemed appropriate by the City of Charleston, WV.



City of Charleston, WV

Click or tap here to enter text.

An attendance sheet provided at the pre-bid meeting shall serve as the official document verifying attendance. Any person attending the pre-bid meeting on behalf of a Vendor must list on the attendance sheet his or her name and the name of the Vendor he or she is representing.

Additionally, the person attending the pre-bid meeting should include the Vendor's E-Mail address, phone number, and Fax number on the attendance sheet. It is the Vendor's responsibility to locate the attendance sheet and provide the required information. Failure to complete the attendance sheet as required may result in disqualification of Vendor's bid.

All Vendors should arrive prior to the starting time for the pre-bid. Vendors who arrive after the starting time but prior to the end of the pre-bid will be permitted to sign in but are charged with knowing all matters discussed at the pre-bid.

Questions submitted at least five business days prior to a scheduled pre-bid will be discussed at the pre-bid meeting if possible. Any discussions or answers to questions at the pre-bid meeting are preliminary in nature and are non-binding. Official and binding answers to questions will be published in a written addendum to the Solicitation prior to bid opening.

3. VENDOR QUESTION DEADLINE: Vendors may submit questions relating to this Solicitation to the City of Charleston's Purchasing Director. Questions must be submitted in writing. All questions must be submitted on or before the date listed below and to the address listed below to be considered. A written response will be published in a Solicitation addendum if a response is possible and appropriate. Non-written discussions, conversations, or questions and answers regarding this Solicitation are preliminary in nature and are nonbinding.

Submitted emails should have the solicitation number and name in the subject line.

QUESTION SUBMISSION DATE:	Wednesday, May 20, 2026
QUESTION SUBMISSION TIME:	1:00pm



City of Charleston, WV

Click or tap here to enter text.

Submit Questions to:

Rodney Burdette, Purchasing Coordinator
City of Charleston
501 Virginia Street East, Room 101 Charleston, WV 25301
Email: bids@cityofcharleston.org

4. BID SUBMISSION: Paper bids will be accepted either by hand delivery or mail. Emailed bids will **not** be accepted. Regardless of delivery method, bids must be **received** by the City on or before the date and time of the bid opening. Any bid received by City staff is considered to be in the possession of the City and will not be returned for any reason.

BID OPENING DATE:	Tuesday, May 26, 2026
BID OPENING TIME:	1:00pm

Submit bids to:

Paper Bids Submitted to:	Rodney Burdette, Purchasing Coordinator City of Charleston 501 Virginia Street East, Room 101 Charleston, WV 25301
Electronic Bids:	www.bidexpress.com

5. PAPER BID DOCUMENTS: Each paper bid must be submitted in a sealed envelope with the following information:

5.1 Marked on the outside of the Envelope:

- A. Vendor Name
- B. Vendor Address
- C. Solicitation Number and Name
- D. BID OPENING DATE and BID OPENING TIME



City of Charleston, WV

Click or tap here to enter text.

5.2 Completed Signed forms to Include with Bid:

1. Pricing Page
2. Contact and Signature Form
3. Purchasing Affidavit
4. Protest Acknowledgement Form
5. Addendum Acknowledgement Form
6. Local Vendor Form (if Applicable)
7. Certification of Insurance
8. Any Required Certifications or License (if Applicable)
9. Any and all additional forms listed in the Specifications or Terms and Conditions
10. Bid Bond (if Applicable)
11. Drug Free Affidavit (if Applicable)
12. Subcontractor List (if Applicable)
13. Federal Funds Addendum (if Applicable)

- 6. ADDENDUM ACKNOWLEDGEMENT:** Changes or revisions to this Solicitation will be made by an official addendum issued by the City. Vendor should acknowledge receipt of all addenda issued with this Solicitation by completing an Addendum Acknowledgment Form, a copy of which is included herewith. Failure to acknowledge addenda may result in bid disqualification. The addendum acknowledgement should be submitted with the bid to expedite document processing.
- 7. BID FORMATTING:** Vendor should type or electronically enter the information onto its bid to prevent errors in the evaluation. Failure to type or electronically enter the information may result in bid disqualification.
- 8. ALTERNATE MODEL OR BRAND:** Any model, brand, or specification listed in this Solicitation establishes the acceptable level of quality only and is not intended to reflect a preference for, or in any way favor, a particular brand or vendor. Vendors may bid alternates to a listed model or brand provided that the alternate is at least equal to the model or brand and complies with the required specifications. The



City of Charleston, WV

Click or tap here to enter text.

equality of any alternate being bid shall be determined by the City at its sole discretion. Any Vendor bidding an alternate model or brand should clearly identify the alternate items in its bid and should include manufacturer's specifications, industry literature, and/or any other relevant documentation demonstrating the equality of the alternate items. Failure to provide information for alternate items may be grounds for rejection of a Vendor's bid.

9. EXCEPTIONS AND CLARIFICATIONS: The Solicitation contains the specifications that shall form the basis of a contractual agreement. Vendor shall clearly mark any exceptions, clarifications, or other proposed modifications in its bid. Exceptions to, clarifications of, or modifications of a requirement or term and condition of the Solicitation may result in bid disqualification.

10. LOCAL VENDOR PREFERENCE: A local vendor may qualify for a competitive advantage applied to its bid when certain conditions are met. The vendor has marked on its bid submission that it is requesting to be considered a local vendor for bid evaluation purposes; the vendor provides documentation evidencing that it has the right to conduct business in the State of West Virginia; and the vendor submits an affidavit confirming that it has paid all applicable business taxes to the City or has a non-delinquent payment plan with the City and has had an active and current business and occupation tax account with the City Collector during the entire preceding one-year period. Competitive advantages shall be applied in the following manner:

1. A competitive advantage of 4% shall be applied to the local vendor's bid when, prior to applying the competitive advantage, the lowest responsible bidder submits a bid that is greater than \$25,000 but does not exceed \$125,000.
2. The competitive advantage of \$5,000 shall be applied to the local vendor's bid when, prior to applying the competitive advantage, the lowest responsible bidder submits a bid that is greater than \$125,000.

11. UNIT PRICE: Unit prices shall prevail in cases of a discrepancy in the Vendor's bid.



City of Charleston, WV

Click or tap here to enter text.

12. BUSINESS & OCCUPATION TAX: The City of Charleston broadly imposes a Business & Occupation Privilege Tax for the act or privilege of engaging in business activities within the City of Charleston. Business & Occupation Tax is measured by the application of rates against gross receipts or gross income of the business. All business activities are classified, and the classifications are significant because the tax liability varies based on the different rates established for the specific types of business activities. Individuals or businesses who do not have a physical location or office located in the City of Charleston are also subject to Business & Occupation Tax if they:

1. Lease tangible personal property to lessees in Charleston
2. Perform construction or installation contracts in Charleston
3. Render services in Charleston.
4. Business & Occupation Tax should be considered when preparing your bid. If you are uncertain as to your business activity or how your business should properly calculate the tax when preparing your bid, please contact us at botax@cityofcharleston.org.

NOTE: No contract or purchase of materials or equipment will be awarded to a company whose Business & Occupation Tax status is delinquent.

13. NON-RESPONSIBLE: The City reserves the right to reject the bid of any vendor as non-responsible in accordance with W. Va. Code of State Rules § 148- 1-5.3, when the City determines that the vendor submitting the bid does not have the capability to fully perform or lacks the integrity and reliability to assure good-faith performance.”

14. ACCEPTANCE/REJECTION: The City may accept or reject any bid as whole, or in part, and may make partial awards if appropriate and necessary based on unit price.

15. YOUR SUBMISSION IS A PUBLIC DOCUMENT: Vendor’s entire response to the Solicitation and the resulting Contract are public documents. As public documents, they will be disclosed to the public following the bid/proposal opening or award of the contract, as required by the competitive bidding laws of West Virginia Code §§5-22-1 et seq., 5G-1- 1 et seq. and the Freedom of Information Act in West Virginia Code §§ 29B-1-1 et seq. DO NOT SUBMIT MATERIAL YOU CONSIDER TO BE CONFIDENTIAL, A TRADE SECRET, OR OTHERWISE NOT SUBJECT TO PUBLIC DISCLOSURE. Submission of any bid, proposal, or



City of Charleston, WV

Click or tap here to enter text.

other document to the City constitutes your explicit consent to the subsequent public disclosure of the bid, proposal, or document. The City will disclose any document labeled “confidential,” “proprietary,” “trade secret,” “private,” or labeled with any other claim against public disclosure of the documents, to include any “trade secrets” as defined by West Virginia Code § 47-22-1 et seq. All submissions are subject to public disclosure without notice.

FEDERAL FUNDS ADDENDUM

REQUIRED CONTRACT PROVISIONS FOR NON-FEDERAL ENTITY CONTRACTS UNDER FEDERAL AWARDS (2 C.F.R. § 200.317):

The City of Charleston, WV and the Vendor awarded this Contract intend that this Contract be compliant with the requirements of the Procurement Standards contained in the Uniform Administrative Requirements, Cost Principles, and Audit Requirements found in 2 C.F.R. § 200.317, et seq. for procurements conducted by a Non-Federal Entity. Accordingly, the Parties agree that the following provisions are included in the Contract.

1. MINORITY BUSINESSES, WOMEN'S BUSINESS ENTERPRISES, AND LABOR SURPLUS AREA FIRMS:

(2 C.F.R. § 200.321)

- a. The City confirms that it has taken all necessary affirmative steps to assure that minority businesses, women's business enterprises, and labor surplus area firms are used when possible. Those affirmative steps include:
 - (1) Placing qualified small and minority businesses and women's business enterprises on solicitation lists;
 - (2) Assuring that small and minority businesses, and women's business enterprises are solicited whenever they are potential sources;
 - (3) Dividing total requirements, when economically feasible, into smaller tasks or quantities to permit maximum participation by small and minority businesses, and women's business enterprises;
 - (4) Establishing delivery schedules, where the requirement permits, which encourage participation by small and minority businesses, and women's business enterprises;
 - (5) Using the services and assistance, as appropriate, of such organizations as the Small Business Administration and the Minority Business Development Agency of the Department of Commerce; and
 - (6) Requiring the prime contractor, if subcontracts are to be let, to take the affirmative steps listed in paragraphs (1) through (5) above.
- b. Vendor confirms that if it utilizes subcontractors, it will take the same affirmative steps to assure that minority businesses, women's business enterprises, and labor surplus area firms are used when possible.

2. DOMESTIC PREFERENCES:

(2 C.F.R. § 200.322)

- a. The City confirms that as appropriate and to the extent consistent with law, it has, to the greatest extent practicable under a Federal award, provided a preference for the purchase, acquisition, or use of goods, products, or materials produced in the United States (including but not limited to iron, aluminum, steel, cement, and other manufactured products).
- b. Vendor confirms that it will include the requirements of this Section 2.

Domestic Preference in all subawards including all contracts and purchase orders for work or products under this award.

c. Definitions: For purposes of this section:

(1) “Produced in the United States” means, for iron and steel products, that all manufacturing processes, from the initial melting stage through the application of coatings, occurred in the United States.

(2) “Manufactured products” means items and construction materials composed in whole or in part of non-ferrous metals such as aluminum; plastics and polymer-based products such as polyvinyl chloride pipe; aggregates such as concrete; glass, including optical fiber; and lumber.

3. BREACH OF CONTRACT REMEDIES AND PENALTIES:

(2 C.F.R. § 200.327 and Appendix II)

In the event the Vendor fails to honor any contractual term or condition, the City may cancel the contract via written notice giving the Vendor a set period of time to cure the stated default. If the Vendor does not cure, the City may re-award the purchase order to the next lowest bidder or put the contract back out to bid with the Vendor failing to honor the contractual obligations becoming responsible for all differences in cost. If such an event occurs, the City may proceed with its debarment procedures as set forth in Section 2-488 of the Municipal Code of the City of Charleston.

4. TERMINATION FOR CAUSE AND CONVENIENCE:

(2 C.F.R. § 200.327 and Appendix II)

The previous Section 3 details termination for cause. In addition, the City may terminate the contract for convenience upon written notice to the Vendor. The Vendor will be paid the contractual rates for all work performed prior to the termination notice.

5. EQUAL EMPLOYMENT OPPORTUNITY:

(2 C.F.R. § 200.327 and Appendix II)

Except as otherwise provided under 41 CFR Part 60, and if this contract meets the definition of “federally assisted construction contract” in 41 CFR Part 60–1.3, this contract includes the equal opportunity clause provided under 41 CFR 60–1.4(b), in accordance with Executive Order 11246, “Equal Employment Opportunity” (30 FR 12319, 12935, 3 CFR Part, 1964– 1965 Comp., p. 339), as amended by Executive Order 11375, “Amending Executive Order 11246 Relating to Equal Employment Opportunity,” and implementing regulations at 41 CFR part 60, “Office of Federal Contract Compliance Programs, Equal Employment Opportunity, Department of Labor.”

6. DAVIS-BACON WAGE RATES:

(2 C.F.R. § 200.327 and Appendix II)

Vendor agrees that if this Contract includes construction, all construction work in excess

of \$2,000 will be completed and paid for in compliance with the Davis–Bacon Act (40 U.S.C. 3141–3144, and 3146–3148) as supplemented by Department of Labor regulations (29 CFR Part 5, “Labor Standards Provisions Applicable to Contracts Covering Federally Financed and Assisted Construction”). In accordance with the statute, contractors must:

- (a) pay wages to laborers and mechanics at a rate not less than the prevailing wages specified in a wage determination made by the Secretary of Labor.
- (b) pay wages not less than once a week.

The decision to award a contract or subcontract is conditioned upon the acceptance of the wage determination. The City will report all suspected or reported violations to the Federal awarding agency.

7. ANTI-KICKBACK ACT:
(2 C.F.R. § 200.327 and Appendix II)

Vendor agrees that it will comply with the Copeland Anti-Kick Back Act (40 U.S.C. 3145), as supplemented by Department of Labor regulations (29 CFR Part 3, “Contractors and Subcontractors on Public Building or Public Work Financed in Whole or in Part by Loans or Grants from the United States”). Accordingly, Vendor, Subcontractors, and anyone performing under this contract are prohibited from inducing, by any means, any person employed in the construction, completion, or repair of public work, to give up any part of the compensation to which he or she is otherwise entitled. The City must report all suspected or reported violations to the Federal awarding agency.

8. CONTRACT WORK HOURS AND SAFETY STANDARDS ACT
(2 C.F.R. § 200.327 and Appendix II)

Where applicable, and only for contracts awarded by the City in excess of \$100,000 that involve the employment of mechanics or laborers, Vendor agrees to comply with 40 U.S.C. 3702 and 3704, as supplemented by Department of Labor regulations (29 CFR Part 5). Under 40 U.S.C. 3702 of the Act, Vendor is required to compute the wages of every mechanic and laborer on the basis of a standard work week of 40 hours. Work in excess of the standard work week is permissible provided that the worker is compensated at a rate of not less than one and a half times the basic rate of pay for all hours worked in excess of 40 hours in the work week. The requirements of 40 U.S.C. 3704 are applicable to construction work and provide that no laborer or mechanic must be required to work in surroundings or under working conditions which are unsanitary, hazardous or dangerous. These requirements do not apply to the purchases of supplies or materials or articles ordinarily available on the open market, or contracts for transportation or transmission of intelligence.

9. RIGHTS TO INVENTIONS MADE UNDER A CONTRACT OR AGREEMENT.
(2 C.F.R. § 200.327 and Appendix II)

If the Federal award meets the definition of “funding agreement” under 37 CFR § 401.2 (a) and the recipient or subrecipient wishes to enter into a contract with a small business firm or nonprofit organization regarding the substitution of parties, assignment or

performance of experimental, developmental, or research work under that “funding agreement,” the recipient or subrecipient must comply with the requirements of 37 CFR Part 401, “Rights to Inventions Made by Nonprofit Organizations and Small Business Firms Under Government Grants, Contracts and Cooperative Agreements,” and any implementing regulations issued by the awarding agency.

10. CLEAN AIR ACT

(2 C.F.R. § 200.327 and Appendix II)

Vendor agrees that if this contract exceeds \$150,000, Vendor is to comply with all applicable standards, orders or regulations issued pursuant to the Clean Air Act (42 U.S.C. 7401–7671q) and the Federal Water Pollution Control Act as amended (33 U.S.C. 1251–1387). Violations must be reported to the Federal awarding agency and the Regional Office of the Environmental Protection Agency (EPA).

11. DEBARMENT AND SUSPENSION

(2 C.F.R. § 200.327 and Appendix II)

The City will not award to any vendor that is listed on the government wide exclusions in the System for Award Management (SAM), in accordance with the OMB guidelines at 2 CFR 180 that implement Executive Orders 12549 (3 CFR part 1986 Comp., p. 189) and 12689 (3 CFR part 1989 Comp., p. 235), “Debarment and Suspension.” SAM Exclusions contains the names of parties debarred, suspended, or otherwise excluded by agencies, as well as parties declared ineligible under statutory or regulatory authority other than Executive Order 12549.

12. BYRD ANTI-LOBBYING AMENDMENT

(2 C.F.R. § 200.327 and Appendix II)

Vendors that apply or bid for an award exceeding \$100,000 must file the required certification. Each tier certifies to the tier above that it will not and has not used Federal appropriated funds to pay any person or organization for influencing or attempting to influence an officer or employee of any agency, a member of Congress, officer or employee of Congress, or an employee of a member of Congress in connection with obtaining any Federal contract, grant or any other award covered by 31 U.S.C. 1352. Each tier must also disclose any lobbying with non-Federal funds that takes place in connection with obtaining any Federal award. Such disclosures are forwarded from tier to tier up to the non-Federal award.

13. PROCUREMENT OF RECOVERED MATERIALS

(2 C.F.R. § 200.327 and Appendix II; 2 C.F.R. § 200.323)

Vendor agrees that it and the City must comply with section 6002 of the Solid Waste Disposal Act, as amended by the Resource Conservation and Recovery Act. The requirements of Section 6002 include procuring only items designated in guidelines of the Environmental Protection Agency (EPA) at 40 CFR part 247 that contain the highest percentage of recovered materials practicable, consistent with maintaining a satisfactory level of competition, where the purchase price of the item exceeds \$10,000 or the value of

the quantity acquired during the preceding fiscal year exceeded \$10,000; procuring solid waste management services in a manner that maximizes energy and resource recovery; and establishing an affirmative procurement program for procurement of recovered materials identified in the EPA guidelines.

14. PROHIBITION ON CERTAIN TELECOMMUNICATIONS AND VIDEO SURVEILLANCE SERVICES OR EQUIPMENT.

(2 C.F.R. § 200.327 and Appendix II; 2 CFR § 200.216)

Vendor and City agree that both are prohibited from obligating or expending funds under this Contract to:

- (1) Procure or obtain;
- (2) Extend or renew a contract to procure or obtain; or
- (3) Enter into a contract (or extend or renew a contract) to procure or obtain equipment, services, or systems that uses covered telecommunications equipment or services as a substantial or essential component of any system, or as critical technology as part of any system. As described in Public Law 115–232, section 889, covered telecommunications equipment is telecommunications equipment produced by Huawei Technologies Company or ZTE Corporation (or any subsidiary or affiliate of such entities).
 - (i) For the purpose of public safety, security of government facilities, physical security surveillance of critical infrastructure, and other national security purposes, video surveillance and telecommunications equipment produced by Hytera Communications Corporation, Hangzhou Hikvision Digital Technology Company, or Dahua Technology Company (or any subsidiary or affiliate of such entities).
 - (ii) Telecommunications or video surveillance services provided by such entities or using such equipment.
 - (iii) Telecommunications or video surveillance equipment or services produced or provided by an entity that the Secretary of Defense, in consultation with the Director of the National Intelligence or the Director of the Federal Bureau of Investigation, reasonably believes to be an entity owned or controlled by, or otherwise connected to, the government of a covered foreign country.

In implementing the prohibition under Public Law 115–232, section 889, subsection (f), paragraph (1), heads of executive agencies administering loan, grant, or subsidy programs shall prioritize available funding and technical support to assist affected businesses, institutions and organizations as is reasonably necessary for those affected entities to transition from covered communications equipment and services, to procure replacement equipment and services, and to ensure that communications service to users and customers is sustained.

City of Charleston:

Vendor Name: _____

By: _____

By: _____

Printed Name: _____

Printed Name: _____

Title: _____

Title: _____

Date: _____

Date: _____

"General Decision Number: WV20260103 01/02/2026

Superseded General Decision Number: WV20250103

State: West Virginia

Construction Type: Highway

County: Kanawha County in West Virginia.

HIGHWAY CONSTRUCTION PROJECTS

Modification Number	Publication Date
0	01/02/2026

ELEC0317-006 10/02/2023

	Rates	Fringes
TRAFFIC SIGNALIZATION:		
Groundsman.....	\$ 22.12	3%+25.60

ENGI0132-002 12/01/2024

	Rates	Fringes
OPERATOR: Crane.....	\$ 40.35	20.30

ENGI0132-003 12/01/2024

	Rates	Fringes
OPERATOR:		
Backhoe/Excavator/Trackhoe.....	\$ 37.59	20.30

ENGI0132-004 12/01/2024

	Rates	Fringes
OPERATOR: Bobcat/Skid		
Steer/Skid Loader.....	\$ 37.59	20.30

ENGI0132-005 12/01/2024

	Rates	Fringes
OPERATOR: Broom/Sweeper.....	\$ 37.59	20.30

ENGI0132-030 12/01/2024

	Rates	Fringes
OPERATOR: Bulldozer.....	\$ 37.59	20.30

ENGI0132-031 12/01/2024		

	Rates	Fringes
OPERATOR: Drill.....	\$ 37.59	20.30

ENGI0132-032 12/01/2024		

	Rates	Fringes
OPERATOR: Forklift.....	\$ 37.59	20.30

ENGI0132-033 12/01/2024		

	Rates	Fringes
OPERATOR: Grader/Blade.....	\$ 37.59	20.30

ENGI0132-035 12/01/2024		

	Rates	Fringes
OPERATOR: Paver/Spreader/Finish equipment(asphalt, aggregate, & concrete).....	\$ 37.59	20.30

ENGI0132-036 12/01/2024		

	Rates	Fringes
OPERATOR: Loader Up to six (6) cubic yard capacity.....	\$ 37.59	20.30

ENGI0132-037 12/01/2024		

	Rates	Fringes
OPERATOR: Mechanic.....	\$ 37.59	20.30

ENGI0132-038 12/01/2024		

	Rates	Fringes
OPERATOR: Post Driver		

(Guardrail/Fences).....\$ 37.59 20.30

LADC0001-002 12/01/2024

Rates Fringes

TRAFFIC CONTROL PERSON.....\$ 27.91 17.40

LADC0001-004 12/01/2024

Rates Fringes

LABORER: Grade Checker.....\$ 29.00 17.40

LADC0001-006 12/01/2024

Rates Fringes

LABORER: Laser Screed Operator...\$ 30.03 17.40

LADC0001-007 12/01/2024

Rates Fringes

LABORER: Asphalt, Includes
Raker, Shoveler, Spreader and
Distributor.....\$ 29.00 17.40

LADC0001-008 12/01/2024

Rates Fringes

LABORER: Guardrail
Installation.....\$ 29.00 17.40

LADC0001-010 12/01/2024

Rates Fringes

LABORER: Pipelayer.....\$ 29.00 17.40

SUWV2022-023 09/11/2024

Rates Fringes

CARPENTER.....\$ 27.72 19.44

CEMENT MASON/CONCRETE FINISHER...\$ 28.67 18.85

IRONWORKER.....\$ 34.87 19.50

LABORER: Common or General.....\$ 25.95	16.30
LABORER: Mason Tender - Cement/Concrete.....\$ 26.59	16.30
OPERATOR: Milling Machine.....\$ 34.18	18.91
OPERATOR: Roller.....\$ 29.38	18.60
TRUCK DRIVER: Dump Truck.....\$ 29.04	16.15

WELDERS - Receive rate prescribed for craft performing operation to which welding is incidental.

=====

Note: Executive Order (EO) 13706, Establishing Paid Sick Leave for Federal Contractors applies to all contracts subject to the Davis-Bacon Act for which the contract is awarded (and any solicitation was issued) on or after January 1, 2017. If this contract is covered by the EO, the contractor must provide employees with 1 hour of paid sick leave for every 30 hours they work, up to 56 hours of paid sick leave each year. Employees must be permitted to use paid sick leave for their own illness, injury or other health-related needs, including preventive care; to assist a family member (or person who is like family to the employee) who is ill, injured, or has other health-related needs, including preventive care; or for reasons resulting from, or to assist a family member (or person who is like family to the employee) who is a victim of, domestic violence, sexual assault, or stalking. Additional information on contractor requirements and worker protections under the EO is available at <https://www.dol.gov/agencies/whd/government-contracts>.

Note: Executive Order 13658 generally applies to contracts subject to the Davis-Bacon Act that were awarded on or between January 1, 2015 and January 29, 2022, and that have not been renewed or extended on or after January 30, 2022. Executive Order 13658 does not apply to contracts subject only to the Davis-Bacon Related Acts regardless of when they were awarded. If a contract is subject to Executive Order 13658, the contractor must pay all covered workers at least \$13.30 per hour (or the applicable wage rate listed on this wage determination, if it is higher) for all hours spent performing on the contract in 2025. The applicable Executive Order minimum wage rate will be adjusted annually. Additional information on contractor requirements and worker protections

under Executive Order 13658 is available at www.dol.gov/whd/govcontracts.

Unlisted classifications needed for work not included within the scope of the classifications listed may be added after award only as provided in the labor standards contract clauses (29CFR 5.5 (a) (1) (iii)).

The body of each wage determination lists the classifications and wage rates that have been found to be prevailing for the type(s) of construction and geographic area covered by the wage determination. The classifications are listed in alphabetical order under rate identifiers indicating whether the particular rate is a union rate (current union negotiated rate), a survey rate, a weighted union average rate, a state adopted rate, or a supplemental classification rate.

Union Rate Identifiers

A four-letter identifier beginning with characters other than "SU", "UAVG", "SA", or "SC" denotes that a union rate was prevailing for that classification in the survey. Example: PLUM0198-005 07/01/2024. PLUM is an identifier of the union whose collectively bargained rate prevailed in the survey for this classification, which in this example would be Plumbers. 0198 indicates the local union number or district council number where applicable, i.e., Plumbers Local 0198. The next number, 005 in the example, is an internal number used in processing the wage determination. The date, 07/01/2024 in the example, is the effective date of the most current negotiated rate.

Union prevailing wage rates are updated to reflect all changes over time that are reported to WHD in the rates in the collective bargaining agreement (CBA) governing the classification.

Union Average Rate Identifiers

The UAVG identifier indicates that no single rate prevailed for those classifications, but that 100% of the data reported for the classifications reflected union rates. EXAMPLE: UAVG-OH-0010 01/01/2024. UAVG indicates that the rate is a weighted union average rate. OH indicates the State of Ohio. The next number, 0010 in the example, is an internal number used in producing the wage determination. The date, 01/01/2024 in the example, indicates the date the wage determination was

updated to reflect the most current union average rate.

A UAVG rate will be updated once a year, usually in January, to reflect a weighted average of the current rates in the collective bargaining agreements on which the rate is based.

Survey Rate Identifiers

The ""SU"" identifier indicates that either a single non-union rate prevailed (as defined in 29 CFR 1.2) for this classification in the survey or that the rate was derived by computing a weighted average rate based on all the rates reported in the survey for that classification. As a weighted average rate includes all rates reported in the survey, it may include both union and non-union rates. Example: SUFL2022-007 6/27/2024. SU indicates the rate is a single non-union prevailing rate or a weighted average of survey data for that classification. FL indicates the State of Florida. 2022 is the year of the survey on which these classifications and rates are based. The next number, 007 in the example, is an internal number used in producing the wage determination. The date, 6/27/2024 in the example, indicates the survey completion date for the classifications and rates under that identifier.

?SU? wage rates typically remain in effect until a new survey is conducted. However, the Wage and Hour Division (WHD) has the discretion to update such rates under 29 CFR 1.6(c)(1).

State Adopted Rate Identifiers

The ""SA"" identifier indicates that the classifications and prevailing wage rates set by a state (or local) government were adopted under 29 C.F.R 1.3(g)-(h). Example: SAME2023-007 01/03/2024. SA reflects that the rates are state adopted. ME refers to the State of Maine. 2023 is the year during which the state completed the survey on which the listed classifications and rates are based. The next number, 007 in the example, is an internal number used in producing the wage determination. The date, 01/03/2024 in the example, reflects the date on which the classifications and rates under the ?SA? identifier took effect under state law in the state from which the rates were adopted.

WAGE DETERMINATION APPEALS PROCESS

1) Has there been an initial decision in the matter? This can be:

- a) a survey underlying a wage determination
- b) an existing published wage determination
- c) an initial WHD letter setting forth a position on a wage determination matter
- d) an initial conformance (additional classification and rate) determination

On survey related matters, initial contact, including requests for summaries of surveys, should be directed to the WHD Branch of Wage Surveys. Requests can be submitted via email to davisbaconinfo@dol.gov or by mail to:

Branch of Wage Surveys
Wage and Hour Division
U.S. Department of Labor
200 Constitution Avenue, N.W.
Washington, DC 20210

Regarding any other wage determination matter such as conformance decisions, requests for initial decisions should be directed to the WHD Branch of Construction Wage Determinations. Requests can be submitted via email to BCWD-Office@dol.gov or by mail to:

Branch of Construction Wage Determinations
Wage and Hour Division
U.S. Department of Labor
200 Constitution Avenue, N.W.
Washington, DC 20210

2) If an initial decision has been issued, then any interested party (those affected by the action) that disagrees with the decision can request review and reconsideration from the Wage and Hour Administrator (See 29 CFR Part 1.8 and 29 CFR Part 7). Requests for review and reconsideration can be submitted via email to dba.reconsideration@dol.gov or by mail to:

Wage and Hour Administrator
U.S. Department of Labor
200 Constitution Avenue, N.W.
Washington, DC 20210

The request should be accompanied by a full statement of the interested party's position and any information (wage payment data, project description, area practice material, etc.) that the requestor considers relevant to the issue.

3) If the decision of the Administrator is not favorable, an interested party may appeal directly to the Administrative Review Board (formerly the Wage Appeals Board). Write to:

Administrative Review Board
U.S. Department of Labor
200 Constitution Avenue, N.W.
Washington, DC 20210.

=====

END OF GENERAL DECISION

"



CITY OF CHARLESTON
DRUG FREE WORKPLACE CONFORMANCE AFFIDAVIT
West Virginia Code §21-1D-5

I, _____, after being first duly sworn, depose and state as follows:

1. I am an employee of _____; and,
(Company Name)
2. I do hereby attest that _____
(Company Name)

maintains a written plan for a drug-free workplace policy and that such plan and policy are in compliance with ***West Virginia Code §21-1D***.

The above statements are sworn to under the penalty of perjury.

Printed Name: _____

Signature: _____

Title: _____

Company Name: _____

Date: _____

STATE OF WEST VIRGINIA,

COUNTY OF _____, TO-WIT:

Taken, subscribed and sworn to before me this _____ day of _____, _____.

By Commission expires _____

(Seal)

(Notary Public)

VENDOR PROTEST ACKNOWLEDGMENT

In the event that any vendor desires to protest City's selection, such vendor (hereinafter "Protestor") shall submit its protest in writing, which must be received by City within seven (7) calendar days of after City Council approves of the award. Provided that the City Manager reserves the right to extend the time for submission of the protest if he determines it is reasonable under the circumstances.

The written protest must be submitted to: **Benjamin Mishoe, City Manager, City of Charleston, 501 Virginia Street, Charleston, WV 25301.**

Only vendors who have submitted a timely and responsive proposal may protest City's selection. No protest may be filed if the RFP is withdrawn or if all proposals received in response to the RFP are rejected.

Protests shall include the following information:

1. The Protestor's name, address, telephone number, and fax number;
2. The solicitation number;
3. A detailed statement of the legal and/ or factual grounds for the protest;
4. Copies of all relevant and supporting documentation, if necessary; and
5. A statement as to the form of resolution or relief sought.

FAILURE TO SUBMIT THIS INFORMATION SHALL BE GROUNDS FOR REJECTION OF THE PROTEST.

The City Manager may refuse to review any protests when the matter involved is the subject of litigation before a court of competent jurisdiction; if the merits have previously been decided by a court of competent jurisdiction; or if it has been decided by the City Manager in a previous protest.

At the time of submitting the written protest, Protestor shall submit a certified check in the amount of one thousand dollars (\$1,000.00) or bond equal to five percent (5%) of the price of the selected proposal, whichever is greater. In the event the proposal being protested is for contracted services, an estimated average of the contract value will be determined in order to calculate the five percent (5%) bond value. This bonding requirement is designed to protect against frivolous claims and unnecessary expenditures of public funds and to allow City to offset any and all costs, fees, expenses or damages of any kind whatsoever incurred by City as the result of an unsuccessful protest.

In the event the protest is unsuccessful, the certified check or bond will be used by City to recoup any and all costs, fees, expenses, or damages of any kind whatsoever incurred by City and related in any way to the unsuccessful protest. Costs, fees, expenses, and damages shall include, but shall not be limited to, increased costs of labor, materials or services resulting from any delay,

professional fees, including, but not limited to, attorney fees, and all costs, fees or expenses of any kind whatsoever related in any way to the unsuccessful protest. By signing this document, Protestor waives the right to receive any money retained by City as set forth herein. If there are any funds remaining after City has recouped amounts as permitted herein, the remaining funds will be returned to Protestor. In the event Protestor is successful, the full amount of the certified check or bond will be returned to Protestor.

Upon receipt of a timely written protest, City shall provide notice of the protest to vendor selected as the successful bidder (hereinafter "Selected Vendor") and provide Selected Vendor with a copy of the written protest and any documents related thereto. **Selected Vendor will have two (2) business days to file a written response to the protest.** A hearing may be held within five (5) business days of the **date of receipt of the written response to the protest by Selected Vendor;** provided that, City may, in its sole discretion, set the date of the hearing beyond the five (5) day time period specified herein if deemed necessary or convenient to do so by City. If a hearing is held, both Protestor and Selected Vendor will have an opportunity to appear and present evidence and testimony in support of their positions. The hearing will be held before the City Manager or his designee. The department head of the department seeking the RFP and the City Attorney shall be in attendance.

A decision will be made by City within five (5) business days of the hearing. Upon a decision having been made, both Protestor and Selected Vendor will be notified in writing of City's decision.

In the event City's selection is reversed, City will reevaluate all proposals which were originally and timely submitted, in accordance with state and city laws and regulations. During the reevaluation, issues addressed during the protest proceedings may be considered.

Once a written protest is filed, no work will be performed by Selected Vendor until such time as City has rendered a final decision on the protest; provided that, if City, in its sole discretion, determines time is of the essence regarding receipt of the goods or completion of the services to be performed, City may permit Selected Vendor to proceed pursuant to its proposal and any Agreement with City, until/unless the protest is successful.

By submitting a proposal, each vendor agrees that the procedure outlined herein is the exclusive remedy available to challenge/protest the award of a contract to a successful bidder. The decision of the city manager is final and is not appealable. Each vendor further agrees that, in the event any qualified vendor fails to submit a written protest and certified check or bond within the time period specified, that vendor thereby forever waives its right to any further claim, action, or remedy, including, but not limited to, the right to bring an action before any administrative agency or any court of competent jurisdiction.

Vendor Signature: _____

Date: _____



ADDENDUM ACKNOWLEDGEMENT FORM

SOLICITATION: 2026-27 ADA Ramp Installation Project

Instructions: Please acknowledge receipt of all addenda issued with this solicitation by completing this addendum acknowledgment form. Check the box next to each addendum received and sign below. Failure to acknowledge addenda may result in bid disqualification.

Acknowledgment: I hereby acknowledge receipt of the following addenda and have made the necessary revisions to my proposal, plans and/or specification, etc.

Addendum Numbers Received: (Check the box next to each addendum received)

Addendum No. 1

Addendum No. 6

Addendum No. 2

Addendum No. 7

Addendum No. 3

Addendum No. 8

Addendum No. 4

Addendum No. 9

Addendum No. 5

Addendum No. 10

I understand that failure to confirm the receipt of addenda may be cause for rejection of this bid. I further understand that any verbal representation made or assumed to be made during any oral discussion held between Vendor's representatives and any state personnel is not binding. Only the information issued in writing and added to the specifications by an official addendum is binding.

Company Name:	
Authorized Signature:	
Printed Name:	
Date:	

NOTE: This addendum acknowledgment should be submitted with the bid to expedite document processing



CITY OF CHARLESTON, WEST VIRGINIA

LOCAL VENDOR AFFIDAVIT

Pursuant to § 2-480 of the Charleston City Code, a Local Vendor may qualify for a competitive advantage applied to its bid when certain conditions are met. One condition requires the vendor to submit this affidavit confirming that (1) the vendor has paid all applicable business taxes to the City or has a non-delinquent payment plan with the City, and (2) the vendor must state that it has had an active and current business & occupation tax account with the City Collector during the entire one-year period prior to the bid opening.

AFFIRMATION: By signing this form, the vendor's authorized signer affirms and acknowledges under the penalty of law for false swearing (W. Va. Code § 61-5-3) that (1) the vendor has paid all applicable business taxes to the City or has a non-delinquent payment plan with the City, and (2) the vendor has had an active and current business & occupation tax account with the City Collector during the entire one-year period prior to the scheduled bid opening for the procurement listed below.

WITNESS THE FOLLOWING SIGNATURE:

Vendor's Corporate Name: _____

Authorized Signature: _____ Date: _____

(Printed Name and Title)

State of _____

County of _____, to wit:

Taken, subscribed, and sworn before me this _____ day of _____, 20 ____.

[SEAL]

Notary Public

My Commission expires _____, 20 ____.

Name of Procurement: 2026-27 ADA Ramp Installation Project Bid Opening Date: 05/26/2026

2026-27 ADA Ramp Installation Project

CITY OF CHARLESTON PURCHASING AFFIDAVIT

VENDOR OWING A DEBT TO THE STATE OR POLITICAL SUBDIVISION:

West Virginia Code § 5A-3-10a provides that: No contract or renewal of any contract may be awarded by the state or any of its political subdivisions to any vendor or prospective vendor when the vendor or prospective vendor or a related party to the vendor or prospective vendor is a debtor and the debt owed is an amount greater than one thousand dollars (\$1,000) in the aggregate.

PUBLIC IMPROVEMENT CONTRACTS & DRUG-FREE WORKPLACE ACT:

If this is a solicitation for a public improvement construction contract, the vendor, by its signature below, affirms that is has a written plan for a drug-free workplace policy in compliance with Article 1D, Chapter 21 of the **West Virginia Code**. The vendor **must** make said affirmation with its bid submission. Further, public improvement construction contracts may not be awarded to a vendor who does not have a written plan for a drug-free workplace policy in compliance with Article 1D, Chapter 21 of the **West Virginia Code** and who has not submitted that plan to the appropriate contracting authority in a timely fashion. For a vendor who is a subcontractor, compliance with Section 5, Article 1D, Chapter 21 of the **West Virginia Code** may take place before their work on the public improvement is begun.

ANTITRUST:

In submitting a bid to any agency for the State of West Virginia, the bidder offers and agrees that if the bid is accepted, the bidder will convey, sell, assign or transfer to the state of West Virginia all rights, title and interest in and to all causes of action it may now or hereafter acquire under the antitrust laws of the United States and the State of West Virginia for a price fixing and/or unreasonable restraints of trade relating to the particular commodities or services purchased or acquired by the state of West Virginia. Such assignment shall be made and become effective at the time the purchasing agency tenders the initial payment to the bidder.

I certify that this bid is made without prior understanding, agreement or connection with any corporation, firm, limited liability company, partnership or person or entity submitting a bid for the same materials, supplies, equipment or services and is in all respects fair and without collusion or fraud. I further certify that I am authorized to sign the certification on behalf of the bidder or this bid.

LICENSING:

Vendors must be licensed and in good standing in accordance with any and all state and local laws and requirements by any state or local agency of West Virginia, including, but not limited to, the West Virginia Secretary of State's Office, the West Virginia Tax Department, the West Virginia Insurance Commission or any other state agencies or political subdivision. Furthermore, the vendor must provide all necessary releases to obtain information to enable the Director or spending unit to verify that the vendor is licensed and in good standing with the above entities.

CONFIDENTIALITY:

The vendor agrees that he or she will not disclose to anyone, directly or indirectly, any such personally identifiable information or other confidential information gained from the agency, unless the individual who is the subject of the information consents to the disclosure in writing or the disclosure is made pursuant to the agency's policies, procedures and rules. Vendor further agrees to comply with the Confidentiality Policies and Information Security Accountability Requirements, set forth in <http://www.state.wv.us/admin/purchase/privacy/noticeConfidentiality.pdf>.

Under penalty of law for false swearing (**West Virginia Code § 61-5-3**), it is hereby certified that the vendor affirms and acknowledges the information in this affidavit and is in compliance with the requirements as stated.

Vendor's Name: _____

Authorized Signature: _____ Date: _____



B&O Tax Overview For Construction Projects

Office of the City Collector

915 Quarrier Street, Suite 4

Charleston, WV 25301

Phone (304) 348-8024 / Fax (304) 347-1810

Website: www.charlestonwv.gov

Email: constructionprojects@cityofcharleston.org



OFFICE OF THE CITY COLLECTOR

915 Quarrier St., Suite 4 | Charleston, WV 25301 | (304) 348-8024 | (304) 348-0734 (fax)

www.charlestonwv.gov

constructionprojects@cityofcharleston.org

Construction Projects Handbook Table of Contents

<u>Topic</u>	<u>Page</u>
Introduction to Charleston Municipal Business and Occupation Tax	1
Business and Occupation Tax Overview	2
Business and Occupation Tax Contracting Frequently Asked Questions	3-4
State of WV Code for Construction Projects	5-8
City of Charleston Municipal Tax Code – Business & Occupation Privilege Tax	9-15
Procedures for Authorization to Release Final Payment/Retainage	16

Appendix:

- (A) Business Registration Application
- (B) Business & Occupation Tax Return and Instructions
- (C) City Service Fee Return and Instructions
- (D) Subcontractor/Supplier/Installation & Service Provider Information Form
- (E) Subcontractor/Supplier/Installation & Service Provider Payment Notification Form
- (F) Example of a Release Letter

INTRODUCTION TO THE CITY OF CHARLESTON MUNICIPAL BUSINESS AND OCCUPATION TAX FOR CONSTRUCTION PROJECTS

Before starting any contracting work in the City of Charleston, all contractors must be registered with the Office of the City Collector (“City Collector”), and be current on all city taxes and fees. The Office of the City Collector is responsible for tracking and collecting all taxes and fees due on any and all construction projects in Charleston. If you are not currently registered with our office, but intend to perform construction work in the city, please complete a *Business Registration Application* and return it to our office.

The purpose of this Project Handbook is to educate individuals performing contracting activities in the City of Charleston of their Business and Occupation (“B&O”) Tax responsibilities, as outlined in Chapter 110, Article II of the Code of the City of Charleston. Included in this handbook are pertinent sections of the state and city code regarding B&O taxes as they relate to contracting activities. In addition, we have also included examples of various forms and documents utilized by our office in our continuing effort to monitor and track your project throughout the construction process.

Any construction project with an estimated cost of \$50,000 or more will be monitored and tracked by our Tax Compliance staff. A Tax Compliance Officer will work closely with you throughout the duration of the project. In order to determine the proper amount of taxes and fees due, we will request complete lists of payments you received during the course of the project, as well as any and all payments made to subcontractors, service providers (architects, engineers, etc.), and suppliers, if applicable.

If you employ, utilize, or enter into a separate contract with any subcontractors, you should withhold at least two percent (2%) of the final contract amount from all subcontractors until a release is issued from the Collectors Office certifying that all taxes and fees due, including final payment/retainage, on this project have been reported/paid. Although the final payment/retainage may not have been issued to the subcontractor, the 2% B&O Tax on the final payment/retainage must be paid prior to the issue of an authorization to release funds. Please complete a *Subcontractor Information Form* (see appendix b) for each contractor, service provider, and supplier you will be using.

We will make every effort to collect the taxes and fees due from your subcontractors. If they fail to report/pay their taxes and fees, you may be held responsible for their liability. Therefore, it is in your best interest as a general contractor, to make sure that all subcontractors that you hire are made aware of their B&O Tax liability to the City.

In addition to registering with the City Collector, all contractors must register with and obtain a current contractor’s license from the State of West Virginia and proof of insurance.

The City Collector and Building Department are located in City Service Center at 915 Quarrier Street, Suite 4. Their offices are open daily Monday through Friday, 8 a.m. until 5 p.m., except holidays. Both departments are ready to assist you with any questions you may have regarding your city responsibilities and obligations.

BUSINESS & OCCUPATION TAX OVERVIEW

The City of Charleston broadly imposes a Business & Occupation (“B&O”) Privilege Tax upon all persons for the act or privilege of engaging in business activities within the City. The term “business” shall include all activities engaged in or caused to be engaged in with the object of gain or economic benefit, either direct or indirect. In determining whether a business is engaged in for “direct or indirect economic gain or benefit”, the lack of profit suffered in said activity is not relevant; nor is it material that the business was engaged in without profit as the primary motivation.

B&O Tax is measured by the application of rates against values of products, gross proceeds of sale, or gross income of the business, as the case may be. All persons engaging in business activities in Charleston are subject to the B&O Tax unless specifically exempted by Chapter 110, Article II, Section 110-63 of the Code of the City of Charleston.

Certain occupations and business activities are classified, and the classifications are significant inasmuch as the tax liability varies because of the different rates established for the types of business activities engaged in by the taxpayer. The business activity usually determines the taxable classification, and where different business activities are conducted, the taxpayer is liable for tax under each taxable classification involved. If you are uncertain as to your business activity or how your business should properly calculate the tax, please contact our office.

B&O Tax returns are due within one month following the end of the taxable quarter. Quarterly payments are due in April, July, October and January. Penalty and interest will be applied against any return that is received after these months. If you did not conduct business activity during a particular reporting period, you still must file a “zero” return.

**BUSINESS & OCCUPATION TAX CONSTRUCTION
FREQUENTLY ASKED QUESTIONS (FAQ'S)**

Q. WHO IS REQUIRED TO FILE?

A. All persons who are engaged in business within the City of Charleston are required to file **B&O Tax returns**. Persons domiciled outside the city limits who (a) lease tangible personal property to lessees in the municipality, or (b) **perform construction or installation contracts in the municipality**, or (c) render services to others therein, are doing business in the municipality, irrespective of the domicile of such persons, and irrespective of whether or not such persons maintain a permanent place of business in the Charleston.

Construction or Installation Contracts in the City of Charleston:

When the business involves a construction or installation contract in the City of Charleston, no deduction from the measure of the tax is permitted, even though the contractor is domiciled outside Charleston, and maintains a place of business outside the municipality.

Construction or Installation Contracts Outside the City of Charleston:

When the business involves a construction or installation contract outside the City of Charleston, the tax does not apply to any part of the income derived therefrom, even though the contractor is domiciled in Charleston, and maintains a place of business therein, which may contribute to the contract performed outside the municipality.

Q. I WAS HIRED BY A GENERAL CONTRACTOR ON A PROJECT, AM I STILL REQUIRED TO PAY B&O TAXES ON THIS PROJECT?

A. Yes. You are responsible for B&O Tax on any and all gross receipts you receive for performing contracting activities in Charleston. This includes any and all work performed for a general contractor. The revenue received must be reported and the taxes due must be paid to the City in the quarter that the funds are received.

Q. MY BUSINESS IS ALREADY REGISTERED WITH THE STATE OF WEST VIRGINIA. DO I STILL NEED TO REGISTER WITH THE CITY OF CHARLESTON?

A. Yes. The City is a separate and distinct entity from the State of West Virginia.

Q. WHAT IS GROSS INCOME?

A. Gross income means the gross receipts of the taxpayer, without any deduction on account of the cost of property sold, the cost of materials used, labor costs, taxes, royalties paid in cash or in kind or otherwise, interest or discount paid or any expense whatsoever.

Q. WHAT IS THE CONTRACTING TAX RATE?

A. Any and all gross receipts from contracting activities are taxed at two percent (2%).

Q. WHEN ARE B&O TAX RETURNS DUE?

A. The returns are due within one month following the end of the taxable quarter. Quarterly payments are due in April, July, October and January. Penalty and interest will be applied against any return that is received after these months.

Q. WHAT ARE THE PENALTY & INTEREST RATES?

A. The tax, if not paid when due, shall bear interest at the rate of 8% per annum from the date the return is due. The penalty shall be 5% for the first month, or fraction thereof, and 1% of the tax for each succeeding month or fraction thereof.

Q. AM I REQUIRED TO FILE EVEN IF I HAD NO INCOME DURING A PERIOD?

A. Yes. If you registered with the City but have no business activity during a particular reporting period, you still must file a “zero” return.

Q. CAN I USE MY CREDIT OR DEBIT CARD TO PAY THE TAX?

A. Yes. Payments can be made on-line at <https://charlestonwvpayments.com>

Q. IS THERE A FEE FOR PAYING ON LINE?

A. Yes. The City of Charleston utilizes the services of Govolution, a third-party provider to process credit cards, branded debit card and ACH payments via this website. Govolution will charge a non-refundable convenience fee per transaction. The convenience fee will vary, depending on the payment type and method of payment. The convenience fee is separate from the primary obligation you are paying and will appear on your statement as a charge to “Govolution”. For a complete list of fees please visit our website at:

<https://charlestonwvpayments.com/payment-fees>

Q. WHAT IF I OVERPAID THE TAX, CAN I RECEIVE A REFUND?

A. Yes. Any taxpayer claiming to have overpaid any tax, interest, or penalty shall file a claim in writing to the City Collector within three years after the due date of the return or within two years from the date the tax was paid, whichever such period expires the later, or if no return was filed by the taxpayer, within two years from the time the tax was paid.

Q. WHAT IF I UNDERPAY OR FAIL TO PAY THE TAX?

A. If you underpay or fail to pay the tax, the City Collector may, at any time, issue an assessment. Upon receiving an assessment, you have thirty (30) days to: (1) remit the assessment balance due, or (2) contest the assessment and file a Petition for Reassessment, either in person or via certified mail. If you fail to comply with either number (1) or (2) above, the assessment will become final and conclusive, and a lien will be filed against you.

STATE OF WEST VIRGINIA CODE

CONSTRUCTION PROJECTS

WEST VIRGINIA CODE: TITLE 110, SERIES 26

Title 110-26-1a.	Definitions
Title 110-26-2	Imposition of privilege tax
Title 110-26-2e	Contracting
Title 110-26-11	Doing business within and without the municipality

West Virginia Code Title 110-26-1a. Definitions

1a.25. The term "Contracting" shall include the furnishing of work, or both materials and work, in the fulfillment of a contract for the construction, alteration, repair, decoration or improvement of a new or existing building or structure, or any part thereof. The term "Contracting" shall also include the alteration improvement or development of real property.

1a.25.1. A person performing any activity described in the preceding paragraph shall report his gross income therefrom under the contracting classification of the municipal business and occupation tax return and shall receive no deduction from gross income on account of any expenses incurred. All income derived from said activity shall be reported under the contracting classification, and the form of contract entered into by the parties shall not be determinative of taxable classification.

1a.25.2. The term "Prime Contractor" means a person engaged in the business of performing for others, contracts for the construction, repairing, decorating or improving of new or existing buildings or other structures under, upon or above real property, either for the work or for a specific portion thereof.

1a.25.3. The word "Subcontractor" means a person engaged in the business of performing a like or similar service for persons other than consumers, either for the entire work or for a specific portion thereof.

1a.25.4. The terms "Prime Contractor" and "Subcontractor" include persons performing labor and services in respect to the moving of earth or clearing of land, razing or moving existing buildings or structures even though such services may not be done in connection with a contract involving the constructing, repairing, or altering of a new or existing building or structure.

1a.25.5. The term "Buildings or Structures" means and includes, but is not limited to, everything artificially built up or composed of parts joined together in some definite manner and attached to real property. It includes not only buildings in the general and ordinary sense, but

also tanks, fences, conduits, culverts, railroad tracks, overhead and underground transmission systems, tunnels, monuments, retaining walls, bridges, trestles, parking lots and pavement for foot or vehicular traffic.

1a.25.6. The term "Contracting, Repairing, Decorating or Improving" of a new part of an existing building or structure or any part thereof, in addition to its ordinary meaning, includes the installing or attaching of any article of tangible personal property in or to real property, whether or not such personal property becomes a part of the realty by virtue of such installation.

1a.26. The term "Speculative Builder" means and includes one who constructs improvements upon real property owned by him for sale or rental. The gross income derived by the speculative builder from the sale of real property upon which the speculative builder has constructed improvements shall be reported under the retail classification on the municipal business and occupation tax form. The sales price is the measure of the tax.

West Virginia Code Title 110-26-2. IMPOSITION OF PRIVILEGE TAX

2.1 The municipal business and occupation tax is a tax imposed upon persons for the act of privilege of engaging in business activities. The tax is measured by the application of rates against values of products, gross proceeds of sale or gross income of the business, as the case may be.

2.1.1 All persons engaging in business activities in a municipality which has ordinances providing for a municipal business and occupation tax pursuant to the authority granted by the Legislature in W.Va. Code §8-13-5 are subject to the municipal business and occupation tax unless specifically exempted by statute or by these rules and regulations.

2.1.2 Certain occupations and business activities are classified, and the classifications are significant inasmuch as the tax liability varies because of the different rates established for the types of business activities engaged in by the taxpayer. The business activity usually determines the taxable classification, and where different business activities are conducted, the taxpayer is liable for tax under each taxable classification involved.

West Virginia Code Title 110-26-2e. Contracting.

2e.1. The business of contracting is taxable under the municipal business and occupation tax law and the gross income derived therefrom must be reported under the contracting classification. See Section 1a of these rules as to definition of "Contracting," "Prime Contractor," "Subcontractor," "Buildings or Structures," "Contracting, Repairing, Decorating or Improving" and "Speculative Builder".

2e.2. Prime and subcontractors, taxable on gross income with no deductions therefrom. -- A prime contractor, one who furnishes work or both materials and work under a written or oral contract, for the construction, alteration, repair, decoration or improvement of a new or existing building or structure or any part thereof, or for the alteration, improvement or development of realty, must report his gross income under the contracting classification without any deduction on account of any expenses incurred. If the prime contractor executes a contract with another for a portion of the job or project, the prime contractor receives no deduction from gross income on account of any payments made to the subcontractor. The subcontractor will also be taxable on his

gross income under the contracting classification.

2e.3. Contract entered into with governments. -- Gross income received by a person for contracting activities performed for the State of West Virginia, the federal government or any of their instrumentalities, agencies, boards, commissions or political subdivisions, etc., or performed for nonprofit organizations is taxable and shall be reported under the contracting classification. The fact that the owner is a governmental unit or a nonprofit organization does not relieve the contractor, subcontractor, suppliers or any other person from liability for municipal business and occupation tax on the full amount of gross income.

2e.4. Form of contract.

2e.4.1. Persons engaged in the contracting business shall report the entire gross income under the contracting classification, regardless of whether the contract is a turnkey contract, lump sum contract, per unit contract, cost plus fixed fee contract, or other contract having a similar basis. Gross income received from a contracting activity must be reported under the contracting classification and the manner of performance, basis of determining cost, fee or income or form of contract shall not alter the definition of contractor or of contracting and shall not change the taxability of such income from the contracting classification to another classification. A contracting activity remains a contracting activity regardless of what the parties may name it and regardless of the manner in which the parties may make payment and perform the work.

2e.4.2. The measure of the tax under the contracting classification is gross income and includes all items of cost where the contractor has incurred liability. The cost of materials and labor can only be exempted from the measure of the tax in those cases where the contractor is not liable to vendors or workmen for payment. In those cases where the contractor contends that he has not incurred a municipal business and occupation tax liability because he acted solely as agent for the owner, the burden of proving alleged principal-agency relationship shall be upon the contractor.

2e.5. Separate contracts for labor and materials.

2e.5.1. In cases where the contractor enters into a separate contract for the furnishing of materials by the contractor and a separate contract for erection of such materials by the contractor, the gross income from both contracts is taxable under the contracting classification, unless it can be proved by the contractor that passage of title of the materials was not dependent upon the erection of the materials by the contractor and that the sale of such materials is, in fact, a separate and distinct transaction, taxable under the municipal business and occupation tax law, as a retail or wholesale sale, as the case may be. The contract to furnish materials shall not be considered a separate and distinct transaction from the contract to erect the same, unless it is established by the contractor to be a complete arm's length transaction with no dependency existing between the contract for materials and the contract for erection. The burden of proving any alleged arm's length transaction shall be upon the contractor.

2e.5.2. A separate purchase order for the furnishing of work or labor and a separate purchase order for the furnishing of materials which constitute the contract(s) between the parties shall be treated in the same manner as set forth in the paragraph above.

West Virginia Code Title 110-26-11. DOING BUSINESS WITHIN AND WITHOUT THE MUNICIPALITY

11.1 Persons domiciled outside a municipality who (a) lease tangible personal property to lessees in the municipality, or (b) perform construction or installation contracts in the municipality, or (c) render services to others therein, are doing business in the municipality irrespective of the domicile of such persons and irrespective of whether or not such persons maintain a permanent place of business in the municipality.

11.2 Persons domiciled outside a municipality who sell tangible personal property to persons in the municipality, may be doing business in the municipality, irrespective of the domicile of such persons and irrespective of whether or not such persons maintain a permanent place of business in the municipality.

11.3 Persons domiciled in and having a place of business in a municipality, who (a) sell or lease personal property to buyers or lessees outside the municipality, or (b) perform construction or installation contracts outside the municipality, or (c) render services to others outside the municipality, are doing business both within and without the municipality. Whether or not such persons are subject to municipal business and occupation tax under the law depends upon the kind of business and the manner in which it is transacted. The following general principles govern in determining tax liability under the municipal business and occupation tax.

11.3.1 When the business involves a construction or installation contract in the municipality, no deduction from the measure of the tax is permitted, even though the contractor is domiciled outside the municipality and maintains a place of business outside the municipality which may contribute to the contract performed in the municipality.

11.3.2 When the business involves a construction or installation contract outside the municipality, the tax does not apply to any part of the income derived therefrom (except such part of the income as may be applicable to the manufacturer in the municipality by the contractor or articles used or incorporated in such construction or installation), even though the contractor is domiciled in the municipality and maintains a place of business therein which may contribute to the contract performed outside the municipality.

CODE OF THE CITY OF CHARLESTON

BUSINESS & OCCUPATION PRIVILEGE TAX

CODE OF THE CITY OF CHARLESTON: SECTION 110

Section 110-31	Definitions
Section 110-56	Business of Contracting
Section 110-63	Exemptions
Section 110-81-84	Computation of tax; quarterly payments; exemptions; return and remittance: extensions of time/payment plans: records, statements and investigations
Section 110-35	Revocation of Licenses and Permits
Section 110-145	Interests and penalties
Section 110-148	Final settlement with contractors; user personally liable.

Code of the City of Charleston Section 110-31. DEFINITIONS

Gross income means the gross receipts of the taxpayer, other than a banking or financial business, received as compensation for personal services and the gross receipts of the taxpayer derived from trade, business, commerce or sales and the value proceeding or accruing from the tangible property (real or personal) or service, or both, and all receipts by reason of the investment of the capital of the business engaged in, including rentals, royalties, fees, reimbursed costs or expenses or other emoluments, however designated, and including all interest, carrying charges, fees or other like income, however denominated, derived by the taxpayer from repetitive carrying of accounts, in the regular course and conduct of his business, and extension of credit in connection with the sale of any tangible personal property or service, and without any deduction on account of the cost of property sold, the cost of materials used, labor costs, taxes, royalties paid in cash or in kind or otherwise, interest or discount paid or any other expense whatsoever. "Gross income" of a banking or financial business is specified in section 110-60.

Contracting means to include the furnishing of work, or both materials and work, in the fulfillment of a contract for the construction, alteration, repair, decoration or improvement of a new or existing building or structure, or any part thereof, or for the alteration, improvement or development of real property.

Prime contractor means a person engaged in the business of performing for others, contracts for the construction, repairing, decorating or improving of new or existing buildings or other structures under, upon or above real property either for the work or for a specific portion thereof. The terms "prime contractor" and "subcontractor" include, but are not limited to, persons performing labor and services in respect to the moving of earth or clearing of land, razing or moving existing buildings or structures even though such services may not be done in connection with a contract involving the constructing, repairing, or altering of a new or existing building or structure.

Subcontractor means a person engaged in the business of performing a like or similar service for persons other than consumers, either for the entire work or for a specific portion thereof.

Buildings or structures means and includes, but is not limited to, everything artificially built up or composed of parts joined together in some definite manner and attached to real property. It includes not only buildings in the general and ordinary sense, but also tanks, fences, conduits, culverts, railroad tracks, overhead and underground transmission systems, tunnels, monuments, retaining walls, bridges, trestles, parking lots and pavement for foot or vehicular traffic.

Contracting, repairing, decorating or improving means of a new part of an existing building or structure or any part thereof, in addition to its ordinary meaning includes, but is not limited to, the installing or attaching of any article of tangible personal property in or to real property, whether or not such personal property becomes a part of the realty by virtue of such installation.

Code of the City of Charleston Section 110-56. BUSINESS OF CONTRACTING

(a) Upon every person engaging or continuing within the city in the business of contracting, the tax shall be equal to two percent of the gross income of the business. A person performing any contracting activity shall report his/her gross income therefrom under the contracting classification of the municipal business and occupation tax return and shall receive no deduction from gross income on the account of any expenses incurred. All income derived from said activity shall be reported under the contracting classification, and the form of contract entered into by the parties shall not be determinative of taxable classification.

(b) Form of contract. Persons engaged in the contracting business shall report the entire gross income under the contracting classification, regardless of whether the contract is a turnkey contract, lump sum contract, per unit contract, cost plus fixed fee contract, or other contract having a similar basis. Gross income received from a contracting activity must be reported under the contracting classification and the manner of performance, basis of determining cost, fee or income or form of contract shall not alter the definition of contractor or of contracting and shall not change the taxability of such income from the contracting classification to another classification. A contracting activity remains a contracting activity regardless of what the parties may name it and regardless of the manner in which the parties may make payment and perform work.

(c) Costs. The measure of the tax under the contracting classification is gross income and includes all items of cost where the contractor has incurred liability. The cost of materials and labor can only be exempted from the measure of the tax in those cases where the contractor is not liable to vendors or workmen for payment. In those cases where the contractor contends that he/she has not incurred a municipal business and occupation tax liability because he/she acted solely as an agent for the owner, the burden of proving alleged principal-agency relationship shall be upon the contractor.

(d) Separate contracts for labor and materials. In cases where the contractor enters into a separate contract for the furnishing of materials by the contractor and a separate contract for erection of such materials by the contractor, the gross income from both contracts is taxable under the contracting classification, unless it can be provided by the contractor that passage of title of the materials was not dependent upon the erection of the materials by the contractor and that the sale of such materials is, in fact, a separate and distinct transaction, taxable under the municipal business and occupation tax law, as a retail or wholesale sale, as the case may be. The contract to furnish materials shall not be considered a separate and distinct transaction from the contract to erect the same, unless it is established by the contractor to be a complete arm's length transaction with no dependency existing between the contract for materials and the contract for erection. The burden of proving any alleged arm's length transaction shall be upon the contractor.

(e) Separate purchase orders. A separate purchase order for the furnishing of work or labor and a separate purchase order for the furnishing of materials which constitutes the contract(s) between the parties shall be treated in the same manner as set forth in the paragraph above.

(f) Prime and subcontractors. A prime contractor, one who furnishes work or both materials and work under a written or oral contract, for the construction, alteration, repair, decoration or improvement of a new or existing building or structure or any part thereof, or for the alteration, improvement or development of realty, must report his/her gross income under the contracting classification without any deduction on account of any expenses incurred. If the prime contractor executes a contract with another for a portion of the job or project, the prime contractor receives no deduction from gross income on account of any payment made to the subcontractor. The subcontractor will also be taxed on his/her gross income under the contracting classification.

(g) Contract entered into with government. Gross income received by a person for contracting activities performed for the State of West Virginia, the federal government or any of their instrumentalities, agencies, boards, commissions or political subdivisions, etc., or performed for nonprofit organizations is taxable and shall be reported under the contracting classification. The fact that the owner is a governmental unit or a nonprofit organization does not relieve the contractor, subcontractor, supplier or any other person from liability for municipal business and occupation tax on the full amount of gross income.

Code of the City of Charleston Section 110-63. EXEMPTIONS

(a) The provisions of this article shall not apply to:

(1) Insurance companies which pay the state a tax upon premiums; provided, that such exemption shall not extend to that part of gross income of insurance companies which is received for the use of real property, other than property in which any such company maintains its office or offices, in the city, whether such income is in the form of rentals or royalties;

(2) Nonprofit cemetery companies organized and operated for the exclusive benefit of their members;

(3) Fraternal societies, organizations and associations organized and operated for the exclusive benefit of their members and not for profit; provided, that this exemption shall not extend to that part of gross income arising from the sale of alcoholic liquor, food and related services of such fraternal societies, organizations and associations which are licensed as private clubs under the provisions of W. Va. Code ch. 60, art. 7;

(4) Corporations, associations and societies organized and operated exclusively for religious or charitable purposes; provided that: the city may impose its business and occupation tax on any activity of a corporation, association or society organized and operated exclusively for religious or charitable purposes only to the extent that the income generated by the activity is subject to taxation under the provisions of section 511 of the Internal Revenue Code of 1986, as amended;

(5) Production credit associations, organized under the provisions of the federal Farm Credit Act of 1933; provided, that the exemptions of this section shall not apply to corporations or cooperative associations organized under the provisions of W. Va. Code ch. 19, art. 4;

(6) Any credit union organized under the provisions of chapter 31 or any other chapter of the Code of West Virginia; provided, that the exemptions of this section shall not apply to corporations or cooperative associations organized under the provisions of W. Va. Code ch. 19, art. 4;

(7) Gross income derived from advertising service rendered in the business of radio and television broadcasting;

(8) The gross income or gross proceeds of sale of a gasification or liquefaction of coal project in the demonstration, pilot or research states; provided, that prior to the commencement of

operation of any such project, the tax commissioner of the state shall have first certified the project as eligible for such exemption; provided, further, that such exemption shall expire seven years from the date the project first receives gross income or gross proceeds from sales; and (9) The first \$5,000.00 of gross income or gross proceeds in each calendar year derived from sales or services by a vendor, as defined in [section 18-1031](#) of this Code, shall be exempt from the tax imposed by this article. The vendor shall file a business and occupation tax return for such gross income or gross proceeds even if such revenue is exempt.

(b) Effective July 1, 2025:

(1) A person engaging in business within the City shall not be subject to the municipal business and occupation or privilege tax imposed by this article for any tax year in which the taxpayer's gross income or gross proceeds is less than \$2,500.00. This exemption shall apply on a prospective basis only and shall not affect liability for any tax periods ending prior to July 1, 2025. The person shall file a business and occupation tax return for such gross income or gross proceeds even if such revenue is exempt; and

(2) The municipal business and occupation or privilege tax imposed by this article shall not apply to the sale of new automobiles that have never been registered in the name of an individual. For the purposes of this subsection, an automobile is a self-propelled vehicle used on the roads and highways by the use of motor vehicle fuel or propelled by one or more electric motors using energy stored in batteries or a combination thereof. An automobile shall include a light-duty truck with an enclosed cabin and an open loading area at the rear and a sport utility vehicle. An automobile does not include a motorcycle. The full exemption shall apply on a prospective basis. For any tax periods ending prior to July 1, 2025, a partial exemption shall apply as set forth in W.Va. Code § 8-13-5. The person shall file a business and occupation tax return for such gross income or gross proceeds even if such revenue is exempt.

(c) An organization is "charitable" for purposes of subdivision (4) of subsection (a) of this section if it satisfies both of the following criteria: (1) it is exempt from Federal Tax, under 26 U.S.C. § 501(c)(3), and (2) its purposes include relief of poverty, advancement of education, advancement of religion, promotion of health, governmental or municipal purposes, or other purposes that are beneficial to the community.

Code of the City of Charleston Section 110-81. TAX CUMULATIVE

(a) The tax imposed by this article shall be in addition to all other licenses and taxes levied by law as a condition precedent to engaging in any business, trade, calling or activity. A person exercising a privilege taxable under this article, subject to the payment of all licenses and charges which are a condition precedent to exercising the privilege tax, may exercise the privilege for the current tax year upon the condition that he shall pay the tax accruing under this article.

(b) *Computation of tax.*

(1) The taxes levied hereunder shall be due and payable in quarterly installments on or before the expiration of one month from the end of the quarter in which they accrue, except as otherwise provided in this subsection. The taxpayer shall, within one month from the expiration of each quarter, make a return reporting the tax for which he/she is liable for such quarter; sign it and mail it, together with any remittance due, in the form required by Section 110-82 of the amount of the tax to the office of the city collector. In reporting and remitting the amount of tax due each quarter, the taxpayer may deduct one-fourth of the total exemption allowed for the year. When the total tax for which any person is liable under this article does not exceed the sum of \$2,500.00 in any year, the taxpayer may pay the tax quarterly as aforesaid or, with the consent in writing of the city collector in the manner prescribed by regulations promulgated pursuant hereto, on an annual basis at the end of the month next following the close of the tax year.

(2) The city collector, if he deems it necessary, based upon past experience with a taxpayer, based on the past practices of a taxpayer, based on the financial condition of the taxpayer, or based on the size of the contract, in order to insure payment of the taxes levied hereunder, may require return and payment under this section for other than quarterly periods. Furthermore, if the city collector deems it necessary to insure payment of the business and occupation tax, they may require a deposit to be paid by the taxpayer prior to when the taxes accrue and are otherwise payable. The amount of the deposit shall be determined and/or based upon the taxpayer's projected gross income or gross proceeds of sale for the applicable tax period. This deposit shall be paid to the office of the city collector, at a date and time, and in a manner determined by the city collector.

(3) Every contractor whose principal business location is outside of the city, shall register with the city collector prior to engaging in the performance of a contract in this city, and the city collector, if he deems it necessary, based on the past experience with a taxpayer, based on the past practices of a taxpayer, based on the financial condition of the taxpayer, or based on the size of the contract, in order to insure payment of the taxes levied hereunder, may also require the following:

(a) At the time of registration, each contractor shall deposit with the city collector six percent of the amount the contractor is to receive for the performance of the contract, which sum shall be held within a contractor's use tax fund pending the completion of the contract.

(b) In lieu of the six percent deposit, each contractor may request the approval of the city collector to provide, in the alternative, a corporate surety bond to be approved by the city collector as to form, sufficiency, value, amount, stability, and other features necessary to provide a guarantee of payment of the tax due the city.

Code of the City of Charleston Section 110-82. RETURN AND REMITTANCE; TAX YEAR

(a) On or before 31 days after the end of the tax year, each person liable for the payment of a tax under Section 110-51 shall make a fourth quarter return, showing the gross proceeds of sale or gross income of business, trade, calling or activity, computing the amount of tax chargeable against him in accordance with the provisions of this article and transmit with his report a remittance in the sum required by this section, covering the remainder of the tax chargeable against him, in the office of the city collector. Such returns shall be verified by the oath of the taxpayer, if made by an individual, or by the oath of the president, vice president, secretary or treasurer of a corporation, if made on behalf of the corporation. If made on behalf of a partnership, joint venture, association, trust or any other group or combination acting as a unit, any individual delegated by such firm, group or unit shall take the oath on behalf of the taxpayer.

(b) The assessment of taxes herein made and the returns required therefore shall be for the year ending December 31. If the taxpayer, in exercising a privilege taxable under this article, keeps the books reflecting the same on the basis other than the calendar year, he may with the written consent of the city collector, make his annual returns and pay taxes for the year covering his accounting period, as shown by the method of keeping his books.

(c) All remittances of taxes imposed by this article shall be made to the city collector, in lawful money of the United States or by bank draft, certified check, cashier's check, money order or certificate of deposit, who shall pay the money into the city treasury, to be kept and accounted for as provided by law.

Code of the City of Charleston Section 110-83. EXTENSIONS OF TIME; PAYMENT PLANS

(a) The city collector, upon approval from city manager, may grant a reasonable extension of time for payment of tax or any installment, or for filing the fourth quarter return or quarterly return required pursuant to this article, on such terms and conditions that he may require. No such extensions shall exceed six months.

(b) The city collector, upon approval from city manager, may extend the time for payment of an amount determined as a deficiency for a period not to exceed 12 months from the date designated for payment of the deficiency. An extension of this time may be granted only where it is clearly established to the satisfaction of the city collector that the payment of a deficiency upon the date designated for payment would result in undue hardship.

(c) If any extension of time is granted for payment of any tax or deficiency, the city collector may require the taxpayer to furnish a bond or other security, in an amount not exceeding twice the amount for which the extension of time for payment is.

Code of the City of Charleston Section 110-84. RECORDS, STATEMENTS AND INVESTIGATIONS

(a) For the purpose of ascertaining the correctness of a tax return or an assessment for the purpose of making an estimate of any taxpayer's liability for the tax administered under this article, the city collector shall have the power to examine or cause to be examined, by any agent or representative designated by the city collector, any books, papers, records, memoranda or other documents bearing upon the matters required to be included in the return and may require the attendance of the person rendering the return or the attendance of any other person having knowledge of the matters contained therein. In connection therewith, the city collector may take testimony and shall have the power to administer an oath to such person.

(b) The city collector may prescribe rules and regulations as to the keeping of records, the content and form of returns and the filing of copies of city business and occupation tax returns and determinations. The city collector may require any person, by notice served upon such person, to make such returns and keep such records as the city collector may deem sufficient to show whether or not such person is liable under this article for such tax.

Code of the City of Charleston Section 110-35. REVOCATION OF LICENSES AND PERMITS

(a) The city collector has the authority to revoke any and all licenses and permits issued by the city in the event a licensee/permittee fails to file any city tax return or fails to pay any delinquent taxes, fees or any interest or penalty thereon due and owing to the city. The city collector has the authority to deny and prevent any and all licenses and permit privileges to those persons who are delinquent in paying taxes, fees or any interest or penalty thereon due and owing the city.

(b) In the event of revocation, the city collector will provide written notice to the licensee/permittee at least five days prior to the contemplated revocation and such notice shall be served by certified mail. The notice shall indicate the time and the place of the revocation review meeting, the general grounds of said contemplated revocation, and shall advise the licensee/permittee of his/her rights to appear at said hearing in person and represented by legal counsel, and to be heard orally upon the merits of his/her defense. The city collector may request legal advice from the city attorney's office, and adopt such procedures for its decorum and the dispatch of business at such hearings as he/she may regard advisable. The revocation decision of

the city collector will be final; provided, that those licensees/permittees who are subject to administrative or judicial appeals, pursuant to Sections 110-113 through 110-115, may utilize these procedures in accordance with the Code, but will not be grounds to delay the revocation process.

(c) Each license or permit that has been revoked pursuant to this section may be re-issued upon payment of all delinquent B&O taxes, fees or any interest or penalty thereon due and owing to the city.

Code of the City of Charleston Section 110-145. INTEREST AND PENALTIES

(a) The tax imposed by this article, if not paid when due, shall bear interest at the rate of at least eight percent per annum from the due date of the return until paid. The city collector may charge an interest rate equal to the adjusted rate charged by commercial banks to large business, in the manner described in W. Va. Code § 11-10-17a.

(b) If any taxpayer fails to make the return or any quarterly installment required by this article, or make his return but fails to remit, in whole or in part, the proper amount of tax, there shall be added to the amount of tax unpaid, from the date such tax should have been paid, a penalty in the amount of five percent of the tax for the first month, or fraction thereof, of delinquency, and one percent of the tax for each succeeding month, or fraction thereof of delinquency provided, that if such failure is due to reasonable cause, the city collector may waive, with final approval from the city manager, in whole or in part, these penalties. Additionally, if the failure to pay is due to fraud or intent to evade any such tax there shall be added an additional penalty of 25 percent of the tax owed, exclusive of penalties.

(c) Interest and penalties may be collected in the same manner as the tax imposed by this article.

Code of the City of Charleston Section 110-148. FINAL SETTLEMENT WITH CONTRACTORS; USER PERSONALLY LIABLE

(a) Any person contracting with a person engaged in a business or service taxed under this article shall withhold payment, in sufficient amount to cover taxes assessed by this article, in the final settlement of such contracts until the receipt of a certificate from the city collector to the effect that all taxes levied and accrued under this article against the contractor have been paid.

(b) If any person shall fail to withhold as provided herein, he shall be personally liable for the payment of all such taxes, and the same shall be recoverable by the city collector by appropriate legal proceedings.

PROCEDURES FOR AUTHORIZATION TO RELEASE FINAL PAYMENT/RETAINAGE

1. The general/prime contractor is the only one that may request an authorization to release final payment/retainage for their subcontractors.
2. A written request must be submitted to the Office of City Collector containing the following information:
 - a) The final contract amount(s) plus any amount(s) not under contract.
 - b) The date(s) and amount(s) of each payment made to all subcontractors.
 - c) The amount(s) held as final payment/retainage.
3. Upon receiving the aforementioned information from the general contractor, the Office of City Collector will request the following information from each subcontractor:
 - a) The final amount paid to you by the general/prime contractor (final contract amount, final paid to date and final payment/retainage).
 - b) The date(s) and amount(s) of each payment you received from the general/prime contractor, and the quarter the Business and Occupation Tax was reported/paid.
 - c) The names and addresses of any subcontractor(s) utilized, if applicable.

EXAMPLE:

<u>Date Received</u>	<u>Amount Received</u>	<u>Qtr. Reported</u>
1/06/04	\$2,000.00	1/04
6/10/04	\$3,000.00	2/04
Retainage	\$ 500.00	Not Reported

4. After receiving the requested information from the subcontractor(s), the Office of City Collector will send the general/prime contractor a *RELEASE APPROVAL* letter stating **all** B & O taxes have been reported/paid on the project, or a *RELEASE DENIAL* letter stating the tax, penalty and interest due on the project. A copy of this letter will also be sent to the subcontractor.

RTS ACCOUNT #: _____
 B&O: Yes / No
 CSF: Yes / No
 BL: Yes / No
 License Fees: _____
 Penalty: _____
 TOTAL PAID: _____
 City Official Use Only

BUSINESS REGISTRATION

City of Charleston
 915 Quarrier St., Suite 4
 Charleston, WV 25301
 Phone: (304)348-8024
 Fax: (304)347-1810
 www.charlestonwv.gov



IMPORTANT: This is a four-page application. All applicable questions must be answered in order to properly classify business activities. Incomplete forms will delay the processing of your application.

Section I. General Information:

1. Company Name: _____
2. DBA: _____
3. Federal Employer ID/Social Security Number*: _____
4. Physical Address of Business: _____
5. City: _____ 6. State: _____ 7. Zip Code: _____
8. Physical Location Phone Number: _____
9. Contact Name: _____ Contact Email: _____
10. Contact Phone Number: _____ Fax: _____ Mobile: _____
11. Mailing Address: _____
12. City: _____ 13. State: _____ 14. Zip Code: _____
15. Ownership Type:
 _____ Proprietorship _____ Partnership _____ Corporation _____ Non-Profit _____ Other
(Include copy of 501(c)(3))
16. Description of Business: _____
17. Date Business Began Operation in Charleston: _____
18. Do you have an employee(s) working out of their home that is located within the city limits of Charleston? Yes / No

If you answered yes to question # 18, please provide a description of the employee(s) job duties including whether or not the job functions generate revenue for the business: _____

RTS ACCOUNT # : _____
 City Official Use Only

19. Does this business own the property on which it is located? Yes / No

If not, who is the owner? _____

Owner's address _____

Owner's phone ## _____

20. Does your business contain vending machines? _____ If so, who is the owner and their address?

*****If you answer YES to Any of the questions below complete Pages 1 - 4 of this application*****
If you answer NO to All of the questions below only complete Pages 1 & 2

21. Do you have a physical location in Charleston? Yes / No

22. Is this a Home Based Business: Yes / No **Home Based Business-** A business that is operated out of a personal residence.

23. Do you own more than 1 rental unit in the City of Charleston? Yes / No If Yes, how many units: _____

Please attach a sheet listing all rental property that you own in the City of Charleston and indicate for each if the rental is for short term (less than 30 days) or long term.

List all principle officers, proprietors, partners or any individual owning more than 25% of the business:

Name _____ Social Security # _____

Address _____ Telephone # _____

Name _____ Social Security # _____

Address _____ Telephone # _____

Name _____ Social Security # _____

Address _____ Telephone # _____

***Privacy Act Statement**

Disclosure of a Social Security Number (SSN) to the City of Charleston is voluntary. If you do not wish to disclose your SSN, you may provide an alternative identification number. The City of Charleston solicits this information pursuant to West Virginia Code § 8-13-13 and the Charleston City Code. The City of Charleston will not disclose your SSN or any other information you provide to any other entity or party.

Authorized Signature of Business: By signing below, I do hereby certify and declare, under penalty of perjury, that the information furnished in this application is true, complete and accurate to the best of my knowledge.

Signature of Business Owner or Authorized Agent

Date

Title

RTS ACCOUNT # : _____

City Official Use Only

Section II. Business License Category: (Only complete this section if you answered yes to Question #21, #22, or #23)

1. Select the appropriate license(s) for your business in **Part A**. All businesses with a storefront or a physical location within the City of Charleston are required to purchase a General Business License. Sales of beer or liquor require an additional license. If your business intends to sell beer or liquor, you **must** attach a copy of your WV ABCC License.

2. Complete **Part B** in its entirety. If your business intends to sell or serve prepared food, you **must** attach a copy of your Kanawha County Health Permit. If your business desires to purchase gold, silver or other precious metals, jewels or other products, you **must** comply with the requirements of §18-863 of the Charleston Municipal Code to report your purchases to the Charleston Police Department. If your business intends to conduct door-to-door sales or engage in home solicitation, a \$3,000 surety bond **must** be posted for **each** sales representative.

3. Sign and date the application in Part C.

Part A:

General Business:

0. GENERAL BUSINESS (\$20.00)

Liquor - Must attach valid WV ABCC License

6. Private Club Less than 1000 members (\$500.00)

7. Private Club More than 1000 members (\$1,250.00)

8. Fraternal, Veterans or Non -Profit Social Clubs (375.00)

Beer - Must attach valid WV ABCC License

1. Distributor (\$250.00)

2. Dispenser (\$100.00)

4. Class A Retail (\$100.00)

5. Class B Retail (\$15.00)

Part B:

A. Does your business purchase gold, silver or other precious metals, jewels or products? Yes / No
If yes, see City Code §18-863

B. Does your business sell? Beer: Yes / No Liquor: Yes / No If Yes, you **Must** attach your ABCC license.

C. Does your business sell or serve prepared food? Yes / No If Yes, you **Must** attach a copy of your Kanawha County Health Permit.

D. Does your business conduct home solicitations or door-to-door sales? Yes / No
If Yes, you **Must** post a \$3,000 surety bond for **each** sales representative.

Part C: Authorized Signature of Business: By signing below, I do hereby certify and declare, under penalty of perjury, that the information furnished in this application is true, complete and accurate to the best of my knowledge.

Signature of Business Owner or Authorized Agent

Date

Title

RTS ACCOUNT # : _____

City Official Use Only

Section III. Planning/Zoning & Property Certification:

It is the responsibility of each applicant upon an **initial** application for a city business license/registration to first ascertain inspection and approval for occupancy of the premises from the Planning/Zoning, Building and Fire Departments. The information in the box below is for a new business, an existing business with a new owner, or an existing business in a new location within the City of Charleston.

*****Do Not Write Inside This Box—For City Official Use Only*****

TO BE COMPLETED BY: ZONING/PLANNING DEPARTMENT

Phone Number: (304)348-8105

1. Was the business location previously occupied? Yes No
2. Is the proposed business a continuation of that previous type of business? Yes No
3. Has the applicant confirmed the zoning of this location? Yes No
4. Does this business conform to the current zoning code? Yes No
5. What is the Zoning District of this proposed business: _____
6. Applicable Section of the Zoning Ordinance: _____
7. Has the Planning Office approved the proposed business? Yes No

If no, the reasons are as follows: _____

Approved By: _____
Planning Official

Date: _____

TO BE COMPLETED BY: BUILDING DEPARTMENT

PHONE NUMBER: (304)348-6833

Approved By: _____
Building Official

Date: _____

TO BE COMPLETED BY: FIRE DEPARTMENT

PHONE NUMBER: (304)348-8058

Approved By: _____
Fire Department Official

Date: _____



BUSINESS AND OCCUPATION TAX RETURN CITY OF CHARLESTON



P.O. Box 7786
 CHARLESTON, WV 25356
 Phone: (304)348-8024 Fax: (304)347-1810
 Pay online at: www.charlestonwvpayments.com

THIS SECTION MUST BE COMPLETED

ACCOUNT #: _____ TAX QUARTER: _____

BUSINESS NAME: _____

ADDRESS: _____

PHONE#: _____

SEE REVERSE
FOR INSTRUCTIONS



COMPUTATION OF QUARTERLY TAX

CLASS CODE	BUSINESS CLASSIFICATION	GROSS AMOUNT	RATE	TAX
			MULTIPLIER	DUE
1	Value of Production of Natural Resources (1%)		0.01	
3	Retailers (1/2 of one percent)		0.005	
4	Wholesalers (15/100 of one percent)		0.0015	
5	Electric Power Companies (4%) <small>(sales & demand charges domestic purposes & commercial lighting)</small>		0.04	
6	Electric Power Companies (3%) <small>(all other sales & demand charges)</small>		0.03	
7	Natural Gas Companies (3%)		0.03	
8	Water Companies (4%)		0.04	
9	All Other Public Utilities (2%)		0.02	
10	Contracting* (2%) <small>(totals from worksheet on back)</small>		0.02	
11	Amusement (1/2 of one percent)		0.005	
12	Service & All Other Business (1%)		0.01	
13	Rents & Royalties (1%)		0.01	
14	Banking & Other Financial Institutions (1%)		0.01	
TOTAL TAX DUE				

*If you are reporting contracting income, you must complete worksheet A on back of form.

PLEASE CHECK BOX IF ADDRESS HAS CHANGED.

UNDER PENALTIES OF PERJURY, I DECLARE THAT I HAVE EXAMINED THIS RETURN AND TO THE BEST OF MY KNOWLEDGE AND BELIEF, IT IS TRUE, CORRECT AND COMPLETE.

A SERVICE FEE WILL BE CHARGED FOR ALL RETURNED CHECKS.

THIS RETURN WITH PAYMENT TO COVER TAX DUE MUST BE RECEIVED WITHIN ONE MONTH FROM END OF PERIOD COVERED.

TYPE OR PRINT NAME AND TITLE OF PREPARER

X

PREPARER'S SIGNATURE AND DATE

SIGNATURE REQUIRED

OFFICE USE ONLY



CITY SERVICE FEE RETURN CITY OF CHARLESTON, WV

P.O. Box 7786
CHARLESTON, WV 25356
Phone: (304)348-8024 Fax: (304)347-1810
www.charlestonwv.gov
Email: citycollector@cityofcharleston.org

THIS SECTION MUST BE COMPLETED

ACCOUNT #: _____ **FEE QUARTER:** _____

Business Name: _____

Mailing Address: _____

CSF REMITTANCE FORM

Form **CSF-2**

See instructions on the
reverse side of this form ►

(Rev.10/2022)

Basis of Computation (choose one)	Weekly <input type="checkbox"/> \$3.00	Bi-Weekly <input type="checkbox"/> \$6.00	Semi-Monthly <input type="checkbox"/> \$6.50	Monthly <input type="checkbox"/> \$13.00
--------------------------------------	--	---	--	--

	A	B	C
	Pay Period or Week Ending Date	Number of Employees/Self- Employed in Charleston	Fee Due
a			
b			
c			
d			
e			
f			
g			
h			
i			
j			
k			
l			
m			
Total Fee Due:			

PLEASE CHECK BOX IF ADDRESS HAS CHANGED.

FOR OFFICE USE ONLY

UNDER PENALTIES OF PERJURY, I
DECLARE THAT I HAVE EXAMINED
THIS RETURN AND TO THE BEST OF
MY KNOWLEDGE AND BELIEF, IT IS
TRUE, CORRECT AND COMPLETE.

TYPE OR PRINT NAME AND TITLE OF PREPARER

X

PREPARER'S SIGNATURE AND DATE

SIGNATURE REQUIRED

A SERVICE FEE WILL BE CHARGED FOR ALL
RETURNED CHECKS.

CSF Instructions for Employer and Self-Employed Remittance Form

1. Complete, sign and date this return. **Failure to complete this form in its entirety and/or enclose your remittance may result in your return being returned to you.**
2. This return must be accompanied by the required remittance no later than the last day of the month succeeding the close of each calendar quarter. Self-employed individuals may request authorization from the City Collector to remit the fees annually.
3. Employers must use this form to remit amounts withheld from employees and amounts received from certain self-employed persons who are members or partners of the Employer. Self-employed persons who are not members or partners of an Employer must use this form to remit the amount of City Service Fee due.
4. This form must be completed based on the **Basis of Computation Method** chosen by the Employer and disclosed on the front of this return, as explained in the administrative regulations.
5. The dates entered in lines "a" through "m", Column A shall be the ending dates for each weekly, bi-weekly, semi-monthly, or monthly pay period, depending on the period used and elected by the Employer, throughout the entire reporting period.
6. Enter the total number of employees/self-employed in Charleston during the pay period or week in Column B lines "a" through "m".
7. Multiply the number of employees/self-employed listed in Column B lines "a" through "m" by the appropriate rate (depending upon the Basis of Computation withholding method chosen) and list the total \$ amount in Column C lines "a" through "m".
8. Add the fee due amount in lines "a" through "m" Column C and enter the amount in the Total Fee Due line. This is the amount owed for the quarter.
9. **Sign the return. THIS RETURN IS INVALID UNLESS IT IS SIGNED.**
10. If your name and/or address printed on the form is incorrect, please mark through the incorrect information and write the correct information in the open space.
11. **Returns postmarked after the due date will be assessed penalty and interest due. An invoice for penalty & interest will be mailed to you.**
12. Please make checks payable to: City of Charleston
13. Mail payments and/or correspondence to: City Collector's Office, P.O. Box 7786, Charleston, WV 25356
14. For additional information, please refer to the City Service Fee Administrative Regulations available at www.charlestonwv.gov or call the Charleston City Collector's Office at (304)348-8024.

Please note that only this remittance form will be accepted. Any change or modification to this form will also result in your return being returned to you.

Privacy Statement Act

Disclosure of a Social Security Number (SSN) to the City of Charleston is voluntary. If you do not wish to disclose your SSN, you may provide an alternative identification number. The City of Charleston solicits this information pursuant to West Virginia Code § 8-13-13 and the Charleston City Code. The City of Charleston will not disclose your SSN or any other information you provide to any other entity or party. The City of Charleston requests this information to facilitate the verification of withholding and payment of service fees.

QUARTER	PERIOD	DUE DATE
1st qtr.	January 1st - March 31st	April 30th
2nd qtr.	April 1st - June 30th	July 31st
3rd qtr.	July 1st - September 30th	October 31st
4th qtr.	October 1st - December 31st	January 31st



OFFICE OF CITY COLLECTOR

915 Quarrier St., Suite 4, Charleston, WV 25301 | (304) 348-8000 Ext. 377 | (304) 348-0734 (fax)|
constructionprojects@cityofcharleston.org

SUBCONTRACTOR INFORMATION FORM

Please Print or Type

Subcontractor Company Name: _____

Federal Employer Identification Number (FEIN): _____

Address: _____

Telephone: _____ Fax: _____ Cell: _____

Email: _____ Contract Amount \$ _____

General Contractor: _____

Project: _____

Brief Description of Work to be Performed: _____

Contract Date: _____ Start Date: _____

Do You Anticipate Change Orders? Yes___ No___ Don't Know _____

Name and Phone Number of Contact Person Regarding This Contract:

Name _____ Phone _____

Signature of Person Completing This Form

****Please Return to the Above Physical Address, Fax Number or Email Address****

SUBCONTRACTOR/SUPPLIER PAYMENT NOTIFICATION FORM (COMPLETE QUARTERLY)

General Contractor: _____

Quarter: _____

Name/Address of Project: _____

	Total Subcontract Amount (\$):	Total Payment(s) Paid this Quarter (\$):	Total Payments Paid to Date (\$):
Subcontractor Name, Address & Contact Information			
Name:			
Address:			
City, State, Zip:			
Contact Name & #:			
Name:			
Address:			
City, State, Zip:			
Contact Name & #:			
Name:			
Address:			
City, State, Zip:			
Contact Name & #:			
Name:			
Address:			
City, State, Zip:			
Contact Name & #:			
Name:			
Address:			
City, State, Zip:			
Contact Name & #:			



OFFICE OF THE CITY COLLECTOR

915 Quarrier St., Suite 4, Charleston, WV 25301 | (304) 348-8000 Ext. 377 | (304) 348-0734 (fax)

December 16, 2025

John Doe Construction
Attn: Tax Department
1234 High Street
Charleston, WV 25302

RE: State Bank Building Project

Dear Mr. Doe:

This is to certify that as of December 16, 2025, the City of Charleston Business and Occupation Privilege Tax accrued on the gross income of \$80,000.00 for the aforementioned project against the hereinafter named taxpayer has been paid in full, based on returns filed by the taxpayer.

John Doe Construction

The execution of this letter is not based on an audit of the taxpayer's records, but only upon information available from a review of the taxpayer's file. If you have any questions, please feel free to contact City Employee, Tax Compliance Officer at (304) 348-8000, ext. 377 or via email at constructionprojects@cityofcharleston.org.

Sincerely,

City Employee
Tax Compliance Office
Office of the City Collector
City Of Charleston